



## CONTENTS

<b>SPECIFICATIONS.....</b>	<b>1</b>
<b>BLOCK AND WIRING DIAGRAM .....</b>	<b>2</b>
<b>PCB INFORMATION .....</b>	<b>3</b>
<b>CIRCUIT DESCRIPTION .....</b>	<b>4</b>
<b>PRINTED CIRCUIT BOARDS.....</b>	<b>5</b>
<b>DISASSEMBLY .....</b>	<b>7</b>
<b>DIAGNOSTIC PROGRAM .....</b>	<b>16</b>
<b>EXPLODED VIEW.....</b>	<b>22</b>
<b>PARTS LIST .....</b>	<b>23</b>
<b>SCHEMATIC DIAGRAMS.....</b>	<b>26</b>

## SPECIFICATIONS

<b>Keyboard</b>	61 standard-size keys; 5 octaves
<b>Key Light System</b>	Can be turned on and off (up to 4 keys can be lit at the same time)
<b>Tones</b>	100 presets
<b>Polyphony</b>	12 notes maximum
<b>3-Step Lesson System</b>	Number of simultaneously lit keys; 4 3-Steps
<b>Playback</b>	1 tune repeat playback
<b>Voice Fingering Guide</b>	On/Off
<b>Auto-accompaniment</b>	
<b>Rhythm Patterns</b>	50 presets
<b>Tempo</b>	Adjustable, (216 steps, = 40 to 255), initial value; 120
<b>Chords</b>	Two systems; CASIO CHORD, FINGERED
<b>Other</b>	Fill-in pattern, Synchro start
<b>Song Bank Tunes</b>	100 tunes
<b>Musical Information Function</b>	Tone, Auto Accompaniment, Song Bank numbers and names; tempo, 3 step lesson display, chord name, fingering, timing indicator, key lighting, voice fingering
<b>Other Functions</b>	
<b>Transpose</b>	F# to C to F: half-note
<b>Tuning</b>	Adjustable A4 = Approx. 440 Hz ± 50 cents, Initial value: A4 = Approx. 440 Hz
<b>Speakers</b>	10 cm diameter × 2 (Output: 2 W+2 W)
<b>I/O Terminals</b>	
<b>Power Supply</b>	DC 9.5 V jack
<b>Headphones/Output</b>	Stereo standard jack (Output is monaural.) Output impedance 78 Ω, output voltage: 4 V (RMS) MAX
<b>Power Supply</b>	
<b>Batteries</b>	2-way 6 AA-size zinc-carbon batteries or alkaline batteries Battery Life: Approximately 4 hours continuous operation on alkaline batteries Approximately 1 hour continuous operation on zinc-carbon batteries
<b>AC Adaptor</b>	AD-E95100L
<b>Auto Power Off</b>	Approximately 6 minutes after the last operation
<b>Power Consumption</b>	9.5 V --- 7.7 W
<b>Dimensions</b>	94.9 × 30.4 × 9.3 cm (37 <sup>3</sup> / <sub>8</sub> × 11 <sup>15</sup> / <sub>16</sub> × 3 <sup>11</sup> / <sub>16</sub> inch)
<b>Weight</b>	Approximately 3.4 kg (7.5 lbs) (without batteries)

# BLOCK AND WIRING DIAGRAM

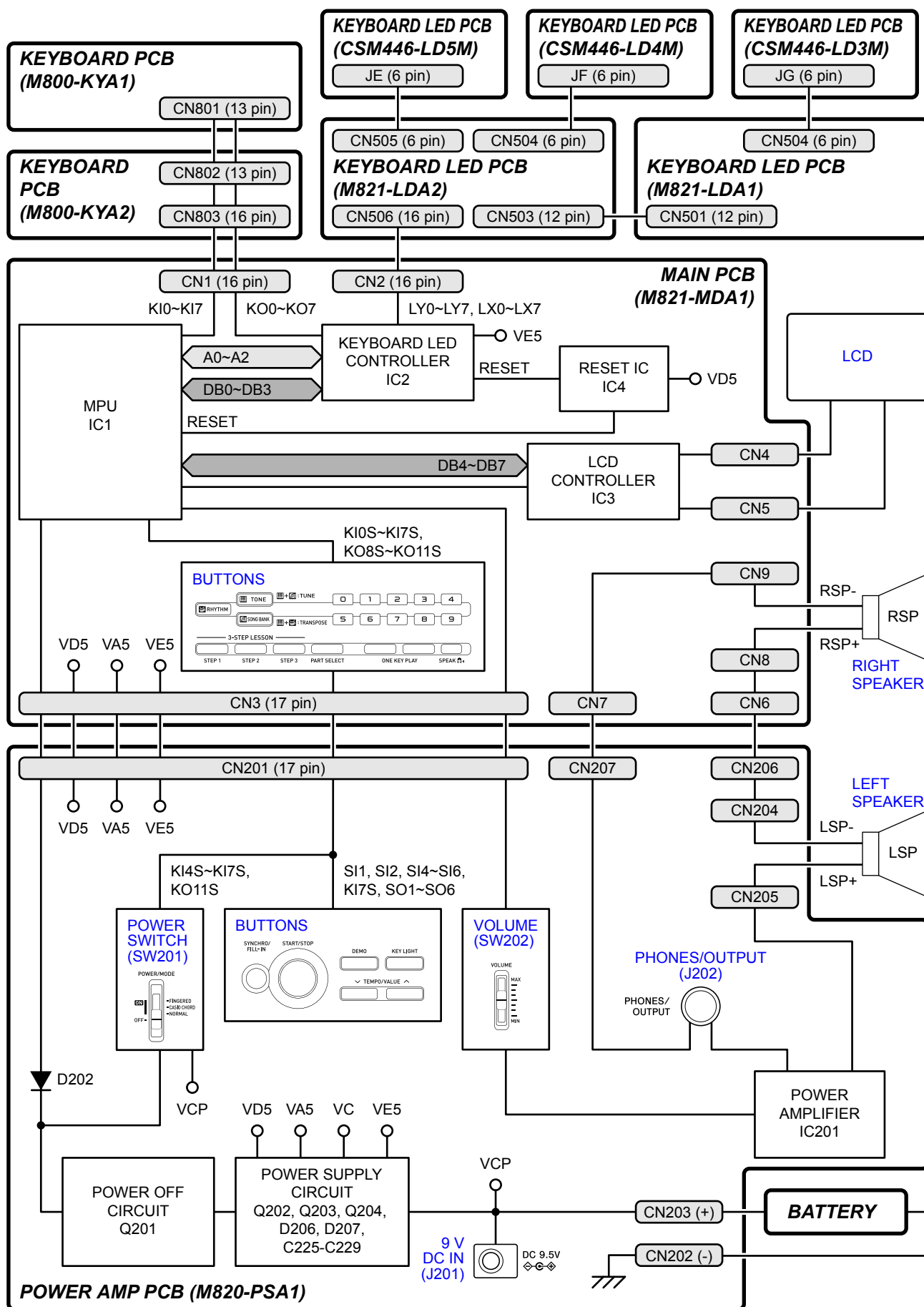

## PCB INFORMATION

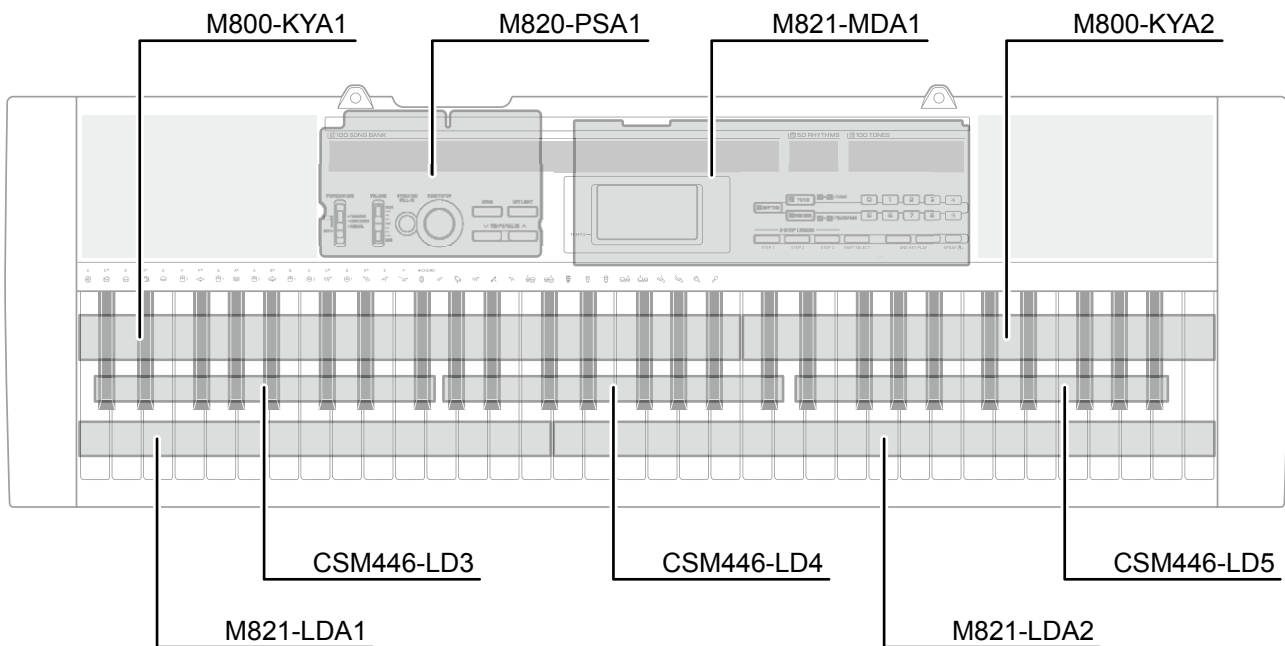

Classification	Parts Name	PCB Name	Components
Main PCB	PCB ASSY/MDA1	M821-MDA1	MPU, LCD Controller, Keyboard LED Controller, Reset IC, Buttons, Right Speaker Terminal
Power Amp PCB	PCB ASSY/PSA1	MX820-PSA1	Power Supply Circuit, Power Amplifier, Power Switch, Volume, Buttons, DC 9.5 V Jack, Left Speaker Terminal, Phones/Output Jack
Keyboard LED PCB	PCB ASSY/LDA	M821-LDA1	Keyboard LED
		M821-LDA2	
	PCB ASSY/LD3M	CSM446-LD3M	
	PCB ASSY/LD4M	CSM446-LD4M	
	PCB ASSY/LD5M	CSM446-LD5M	
Keyboard PCB	PCB ASSY/KYA	M800-KYA1	Keyboard
		M800-KYA2	

## CIRCUIT DESCRIPTION

### ■ KEY MATRIX

	KC0	KC1	KC2	KC3	KC4	KC5	KC6	KC7
KI0	C2	C2#	D2	D2#	E2	F2	F2#	G2
KI1	G2#	A2	A2#	B2	C3	C3#	D3	D3#
KI2	E3	F3	F3#	G3	G3#	A3	A3#	B3
KI3	C4	C4#	D4	D4#	E4	F4	F4#	G4
KI4	G4#	A4	A4#	B4	C5	C5#	D5	D5#
KI5	E5	F5	F5#	G5	G5#	A5	A5#	B5
KI6	C6	C6#	D6	D6#	E6	F6	F6#	G6
KI7	G6#	A6	A6#	B6	C7			

### ■ NOMENCLATURE OF KEYS

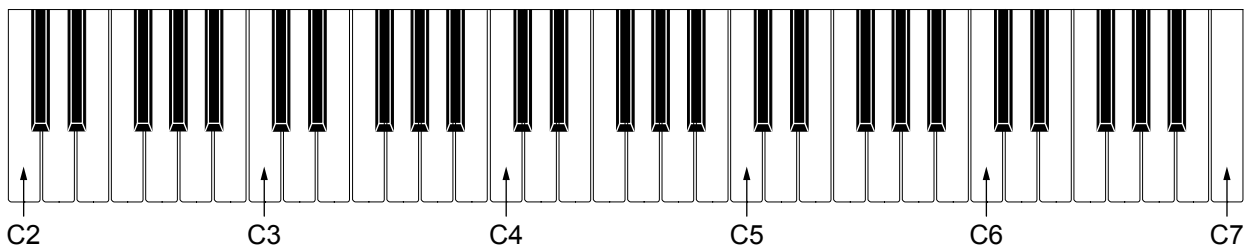

### ■ BUTTON MATRIX

	KO8S	KO9S	KO10S	KO11S
KI0S	0	5	TONE	STEP 1
KI1S	1	6	RHYTHM	STEP 2
KI2S	2	7	SONG BANK	STEP 3
KI3S	3	8	PART SELECT	SPEAK
KI4S	4	9	ONE KEY PLAY LEFT	FINGERED (POWER/MODE)
KI5S	START/STOP	TEMPO DOWN/ VALUE	ONE KEY PLAY RIGHT	CASIO CHORD (POWER/MODE)
KI6S	TEMPO UP/ VALUE		KEY LIGHT	NORMAL (POWER/MODE)
KI7S		SYNCHRO/ FILL-IN	DEMO	OFF (POWER/MODE)

PRINTED CIRCUIT BOARDS

Main PCB: M821-MDA1

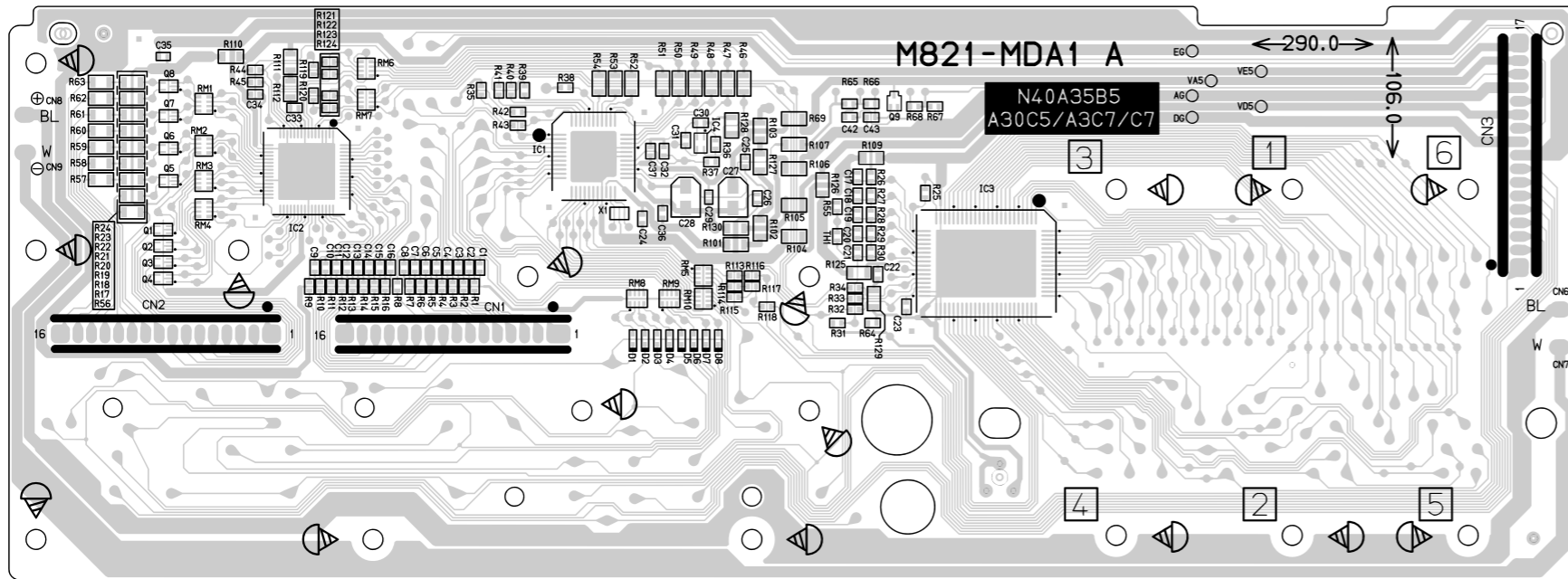

Sub PCB: M820-PSA1

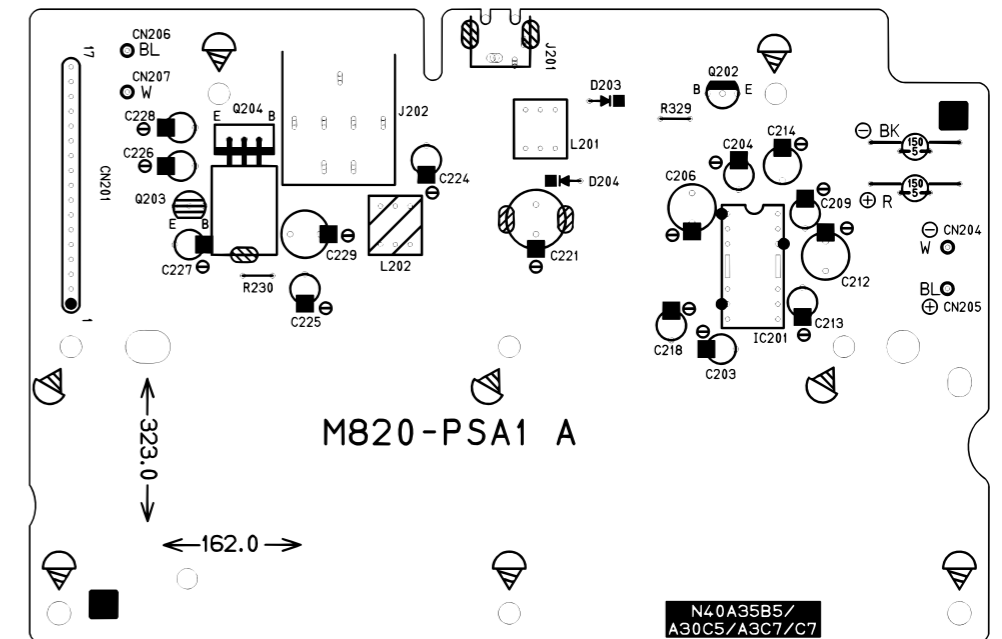
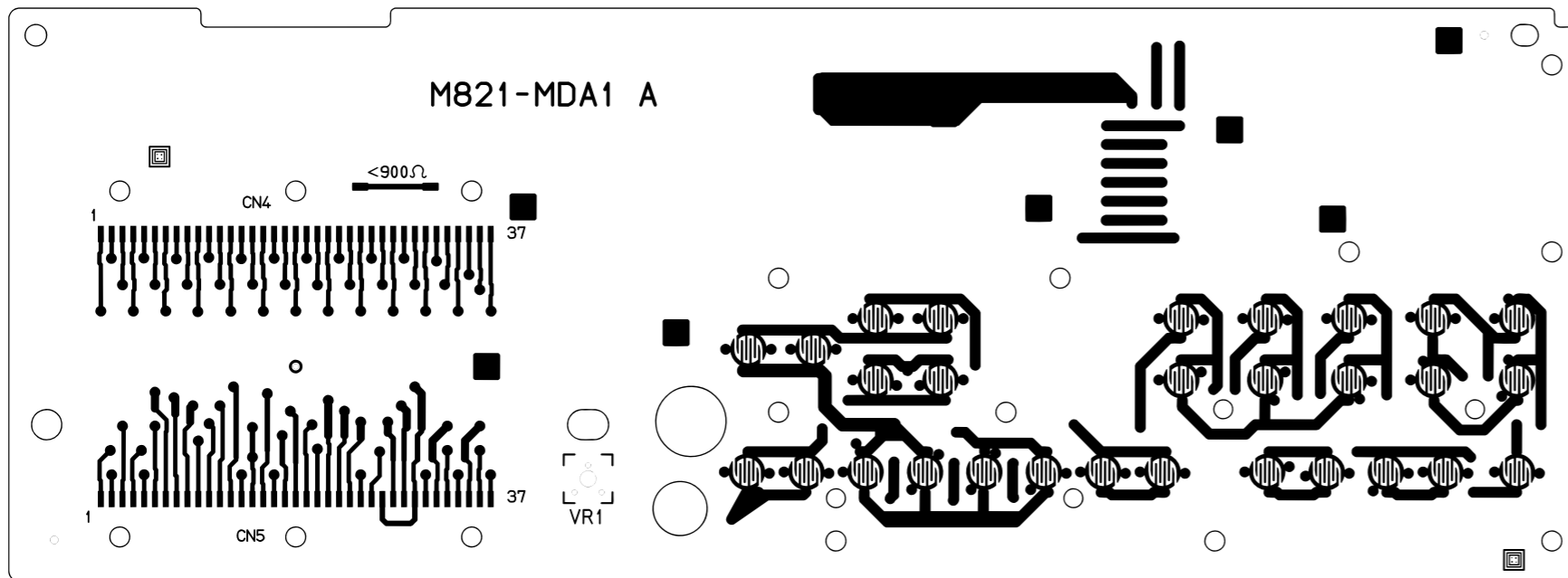
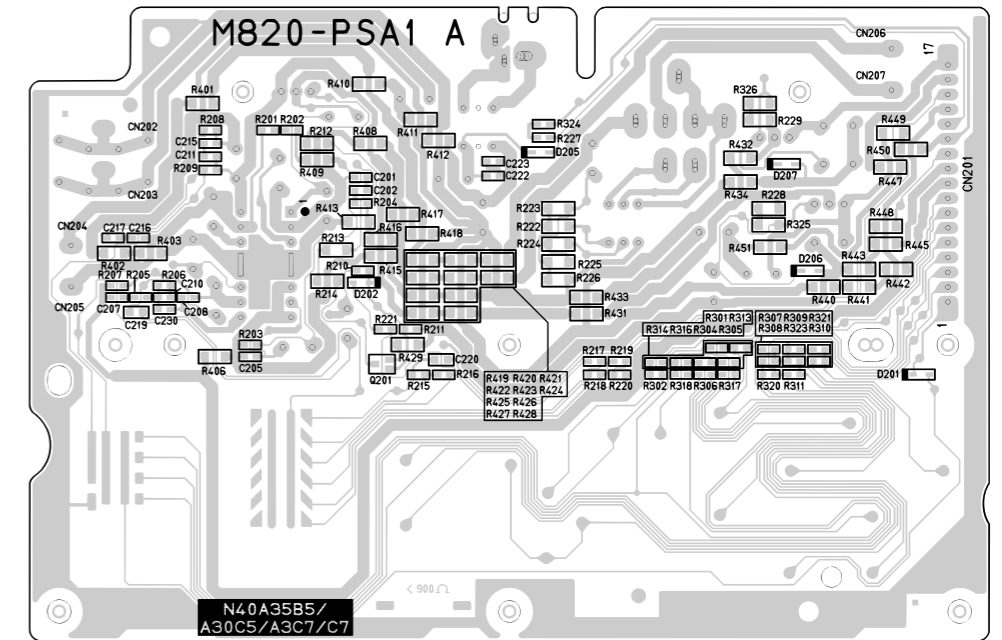

Keyboard LED PCB: M821-LDA1

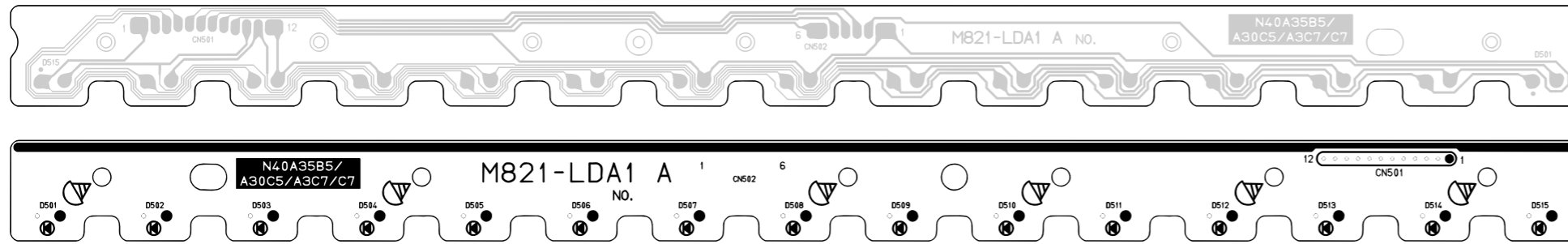

Keyboard LED PCB: M821-LDA1

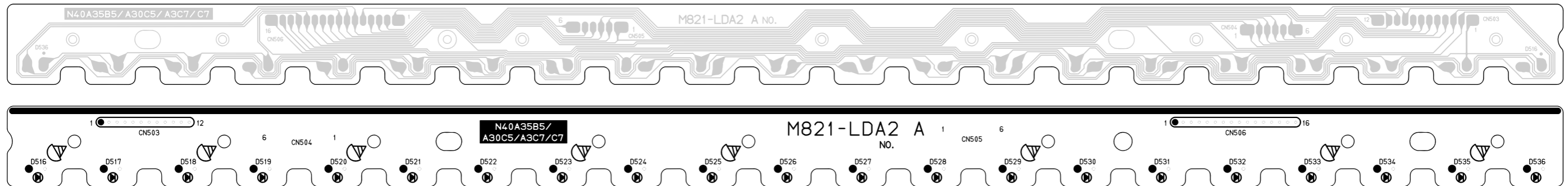

Keyboard PCB: M800-KYA1

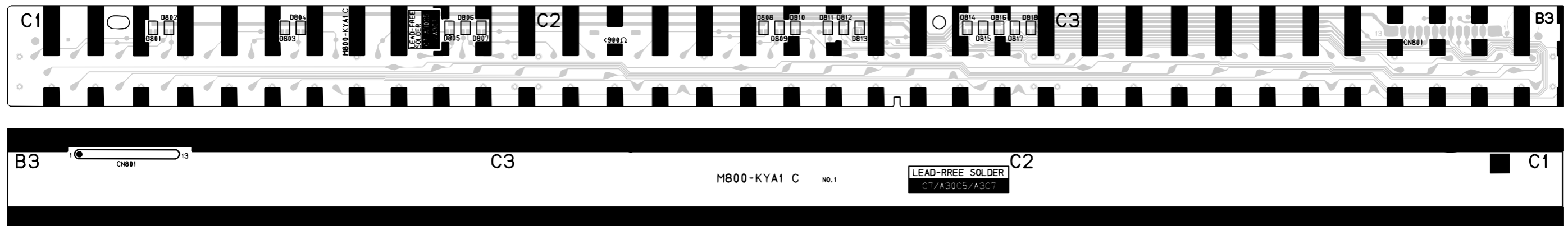

Keyboard PCB: M800-KYA2

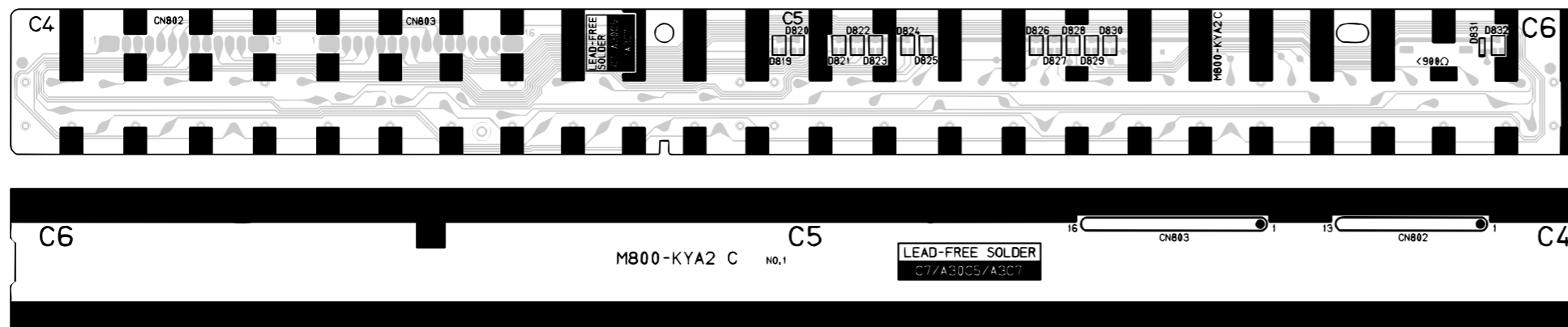



## DISASSEMBLY

### ■ CAUTION

- The photos show a prototype. The appearance of the instrument, such as color, may differ from the actual model.
- To avoid damages to the instrument and the floor, lay the instrument on a mattress or blanket before starting disassembling.
- There are several kinds of screws. Be sure to use the correct type of screws when reassembling. It is advisable to sort the screws as shown below after removing them.

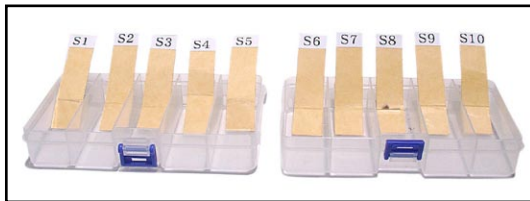

- If a screw cap is attached to a screw, be sure to reattach the screw cap when reassembling.

### ■ BEFORE STARTING REPAIR OR SERVICING

- Remove the AC adaptor or the AC cord.
- Remove accessories such as the music stand.

## ■ DISASSEMBLY

### A. PANEL UNIT

A-1. Undo 11 screws on the bottom surface of the main unit

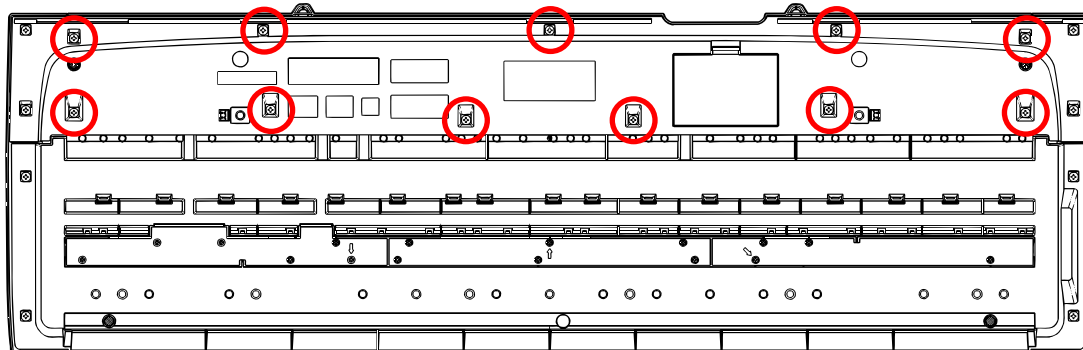

A-2. When replacing the keyboard LED PCBs, undo 16 screws and then remove the L-COVER-A/B/C.

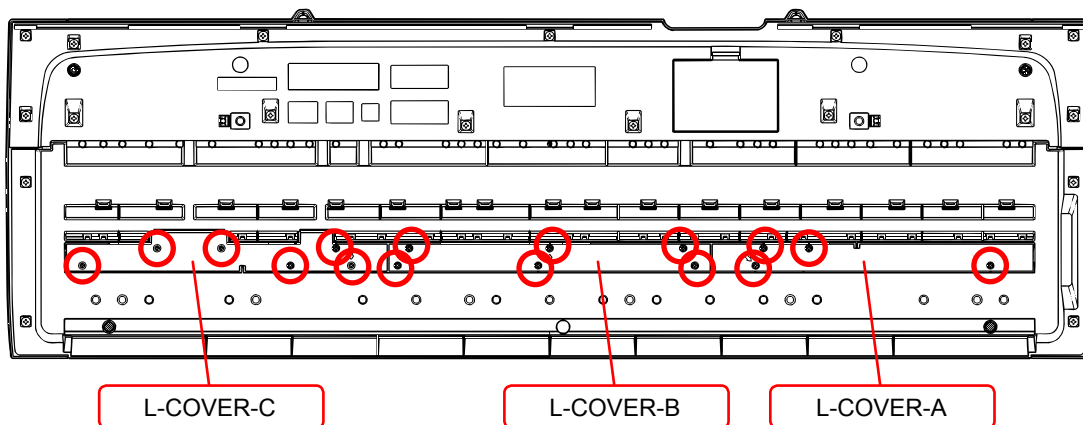

#### <Caution for installing L-COVER-A/B/C>

To install the L-COVER-A/B/C, tighten the screws indicated with arrows engraved on each cover first.

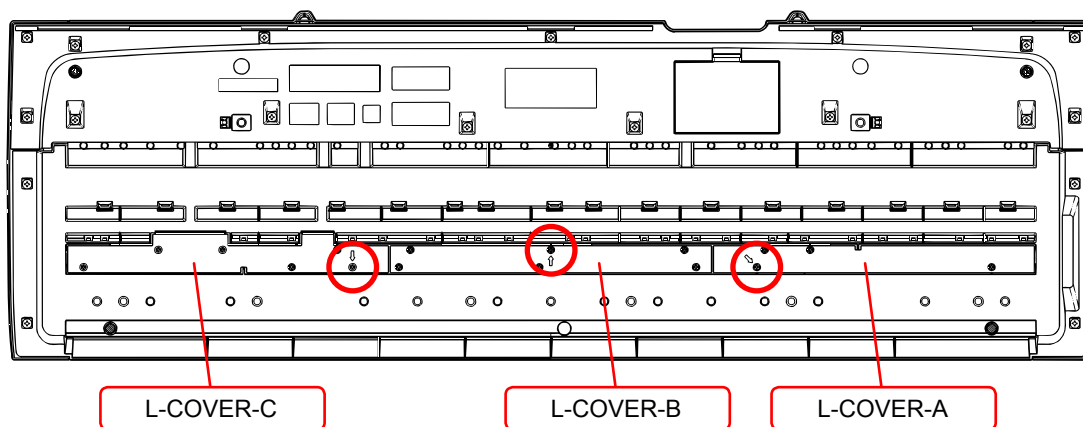

A-3. Turn over the panel unit.

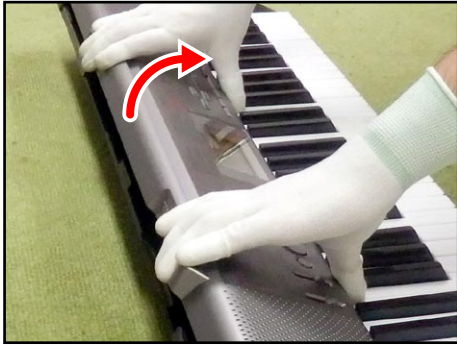

A-4. Unsolder two battery lead wires.

A-5. Unsolder two FFCs.

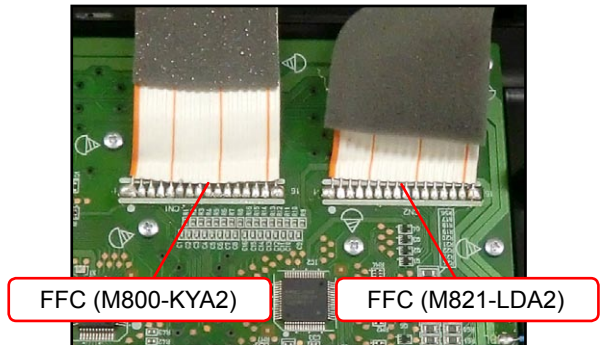
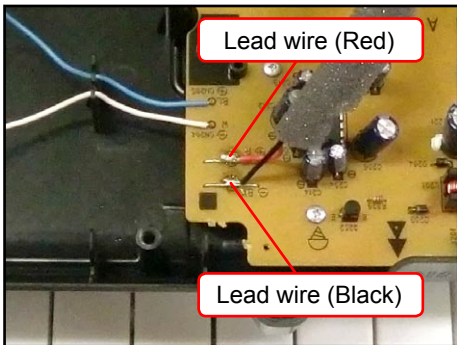

A-6. Remove the panel unit.

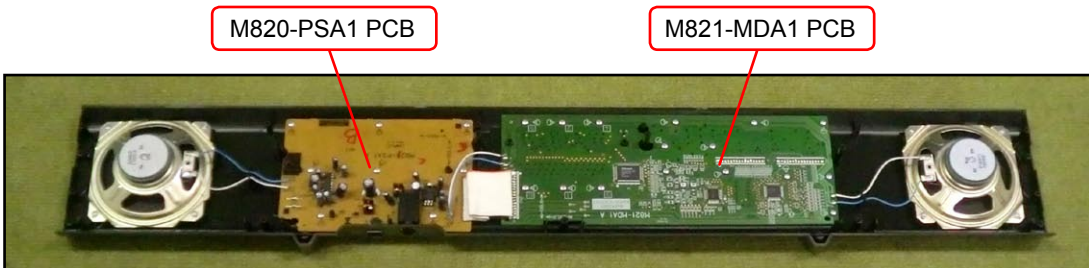

## B. MAIN PCB (M821-MDA1)

---

B-1. Unsolder two FFCs.

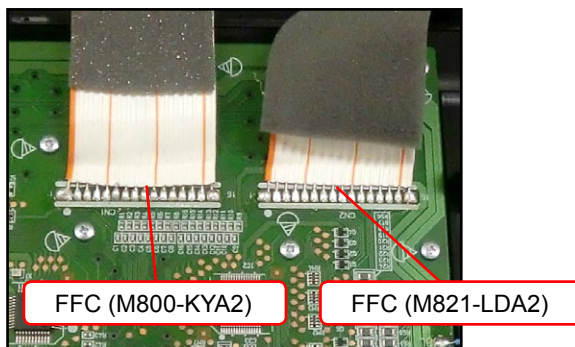

B-2. Unsolder two lead wires and one FFC.

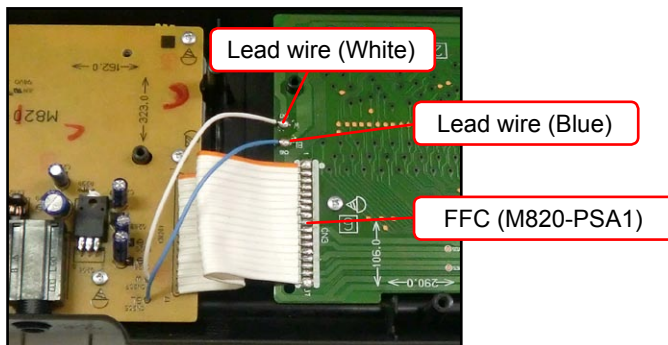

B-3. Unsolder two lead wires connected to the right speaker.

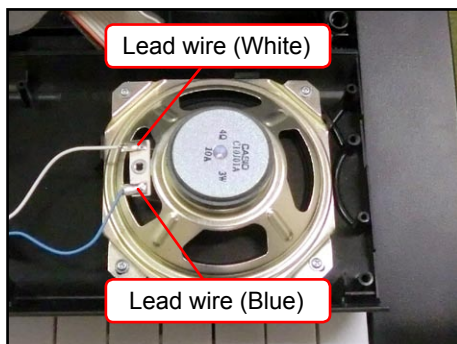

B-4. Undo 16 screws and then remove the M821-MDA1 PCB, rubber keys and LCD.

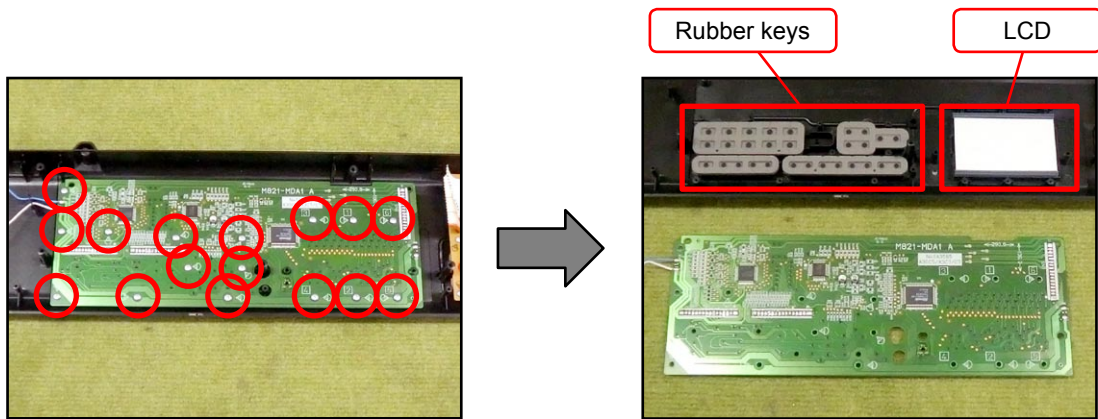

**<Caution for installing M821-MDA1 PCB>**

To install the M821-MDA1 PCB, tighten the screws for the LCD part in the order shown in the right. If not tighten correctly, it may cause the LCD display errors.

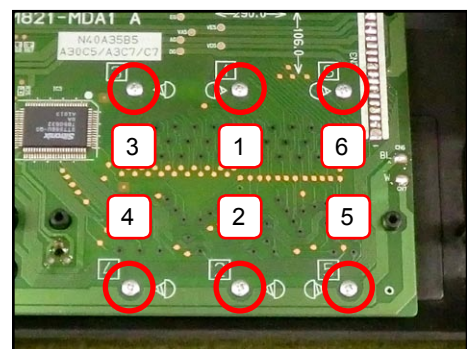

## C. POWER AMP PCB (M820-PSA1)

C-1. Unsolder two lead wires and one FFC connected to the M821-MDA1 PCB.

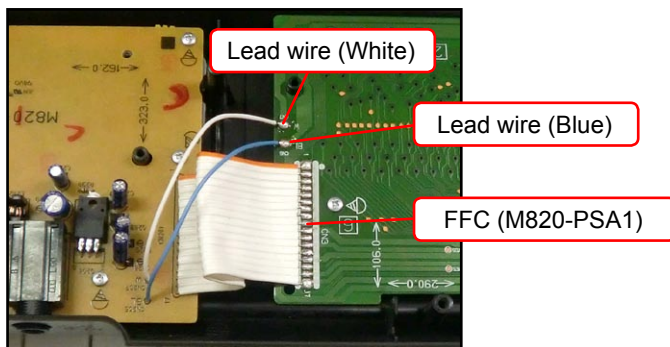

C-2. Unsolder two lead wires connected to the left speaker.

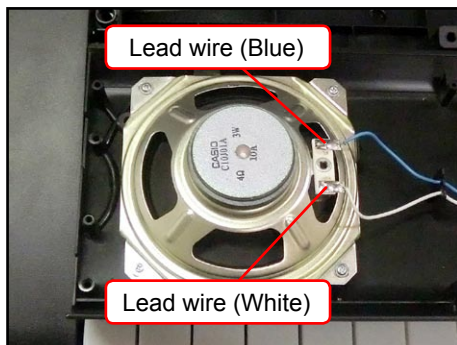

C-3. Undo eight screws and then remove the M820-PSA1 PCB, rubber keys and switches.

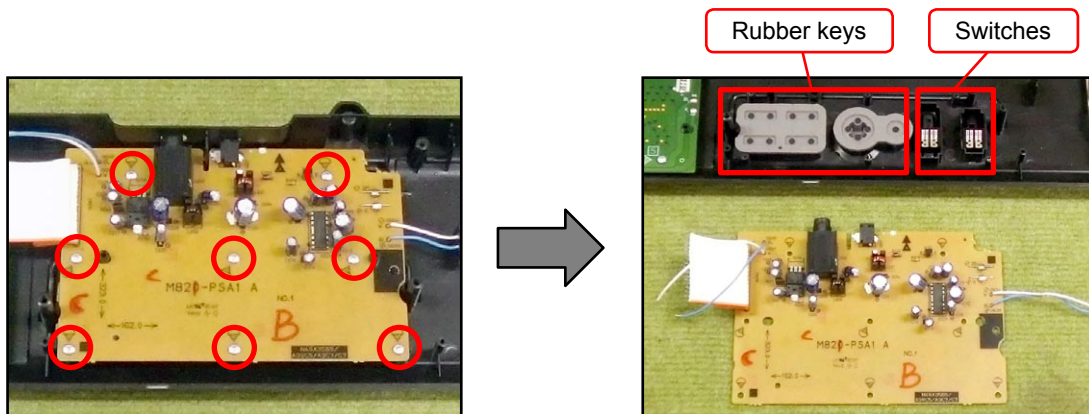

## D. KEYBOARD

D-1. Undo eight screws and then remove the side panels.

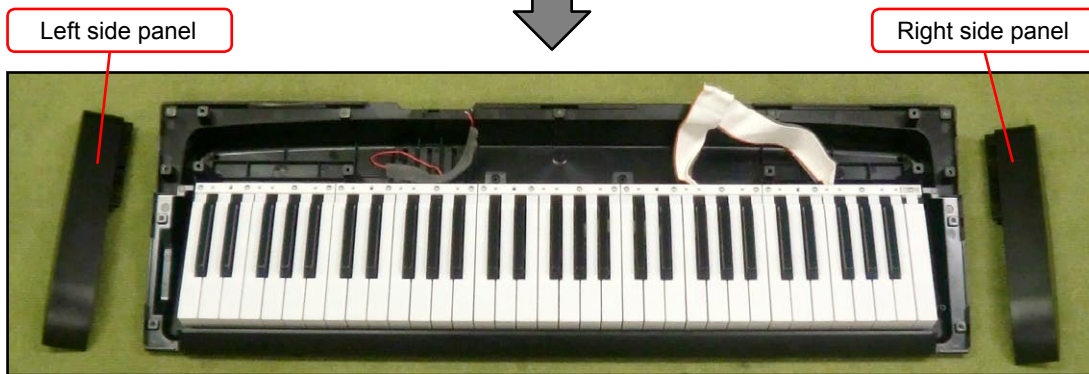
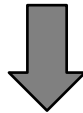
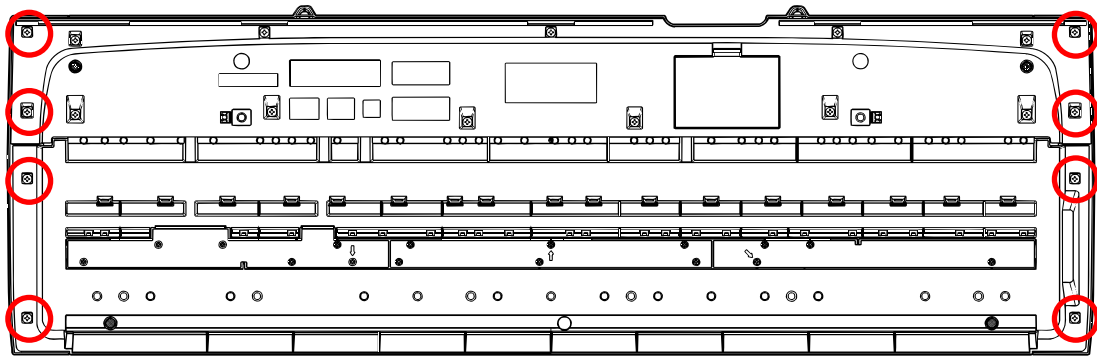

D-2. Undo 21 screws and then remove the white keys and black keys.

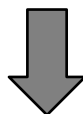
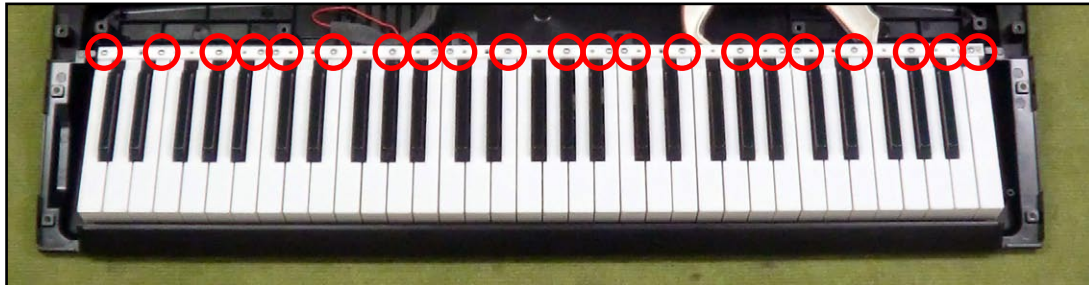

## E. KEYBOARD PCB (M800-KYA1/KYA2)

E-1. Disengage the hooks and then remove the M800-KYA1/KYA2 PCBs.

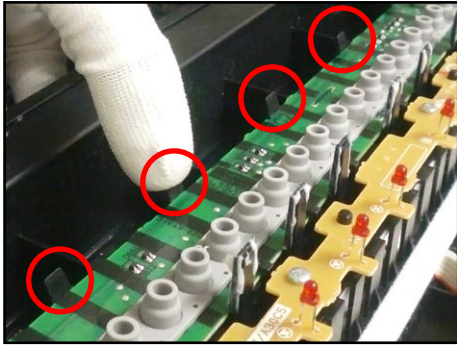

E-2. Remove five rubber contact strips.

**NOTE:** One rubber contact strip differs in length.

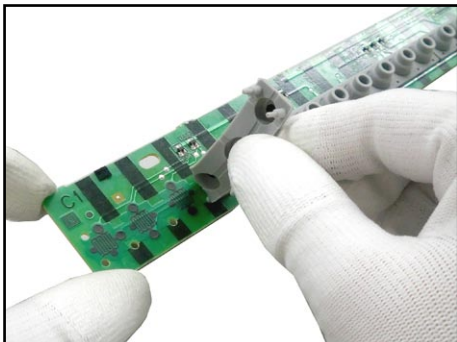
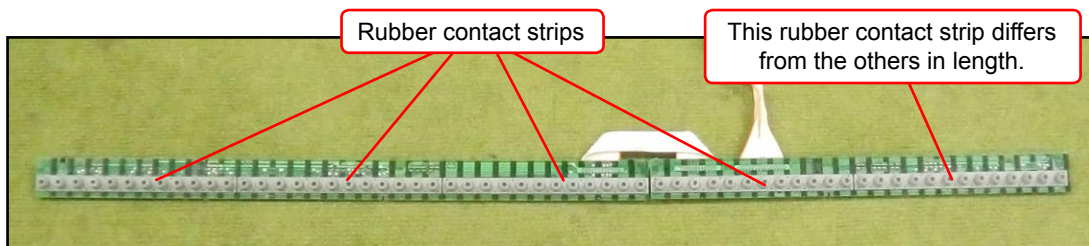

### <How to install rubber contact strips>

Lightly insert the tip of a rubber contact strip into the PCB. Pull the tip from the back of the PCB and install it using a tool such as tweezers. Do not forcibly pull it.

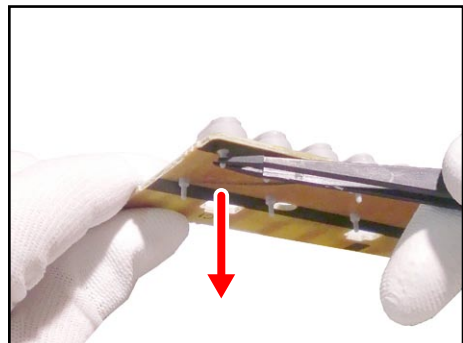



## F. KEYBOARD LED PCB (M821-LDA1/LDA2, CSM446-LD3M/LD4M/LD5M)

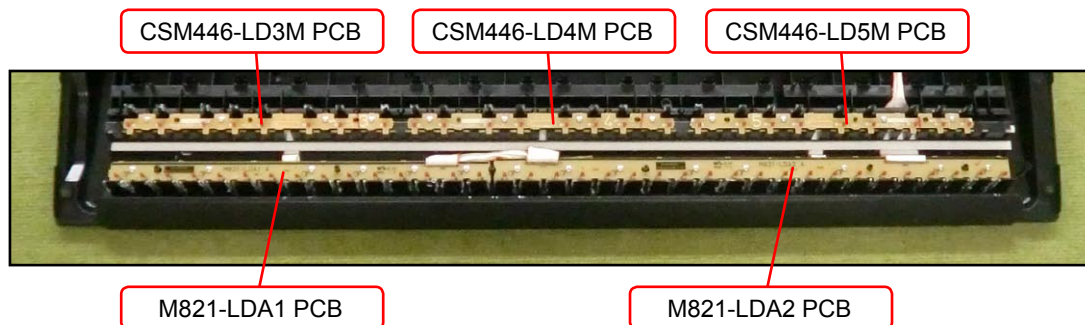

F-1. Undo 14 screws on the M821-LDA1/LDA2 PCBs.

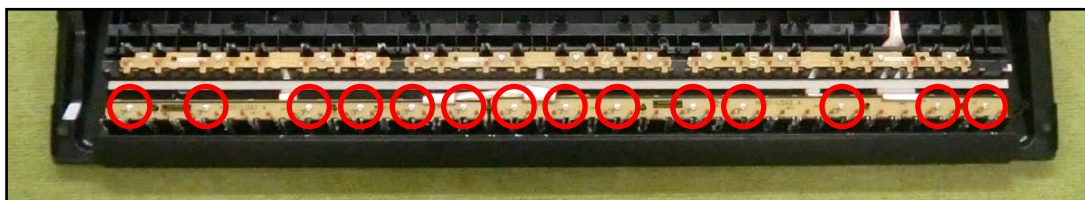

F-2. Turn over the M821-LDA1/LDA2 PCBs.

**NOTE:** Do not touch the LEDs.

F-3. Unsolder three FFCs and then remove the M821-LDA1/LDA2 PCBs.

**NOTE:** After repairing, arrange the FFCs again.

F-4. Undo 12 screws on the CSM446-LD3M/LD4M/LD5M PCBs and then remove the CSM446-LD3M/LD4M/LD5M PCBs.

**NOTE:** After repairing, arrange the FFCs again.

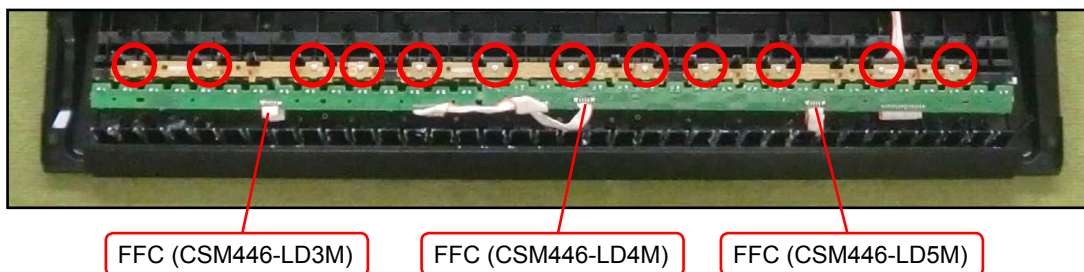

## DIAGNOSTIC PROGRAM

### ■ INITIAL SETTING

- (1) Connect the AC adaptor.
- (2) Turn the volume to the maximum.

### ■ HOW TO START THE DIAGNOSTIC PROGRAM

- (1) Hold down the “0” and “START/STOP” buttons at the same time, to turn the power ON.

**NOTE:** Set the mode switch to the “NORMAL”.

**NOTE:** Be sure to turn off the power when the test is finished.

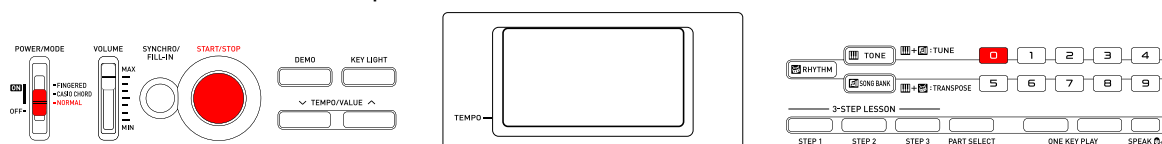

- (2) Release the “0” and “START/STOP” buttons.
- (3) After the diagnostic program is launched, the test menu appears.

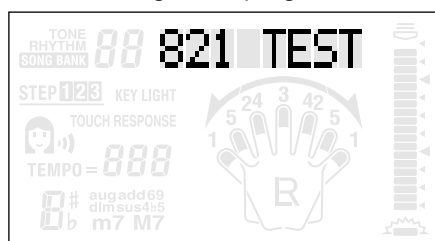

### ■ TEST ITEMS

Pushing a test button enables the corresponding test item to be tested.

Test Items	Buttons	Note
Mode Switch Check	—	
Button Check	0	
ROM Version Check	1	
Keyboard LED Check	TONE	
LCD Check	STEP 1	
Auto Power Off Check	PART SELECT	

This diagnostic program does not test the following items.

Check the functions with regular power-on state.

Test Items	Buttons	Note
Keyboard Check	—	
Headphones Check	—	Headphones

## ■ DIAGNOSTIC PROGRAM

### A. MODE SWITCH CHECK

A-1. Switch the mode switch and check that the following screen appears on the LCD.

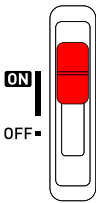
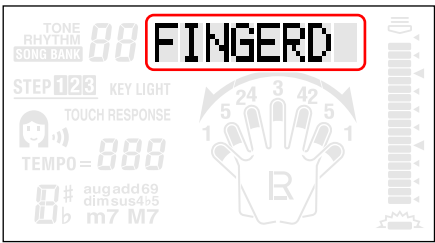
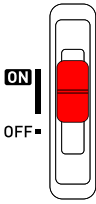
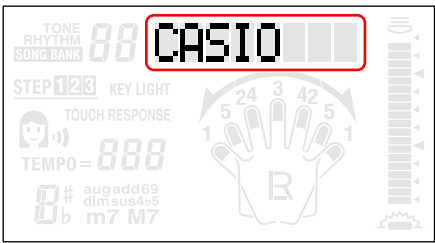
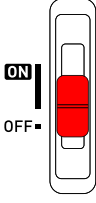
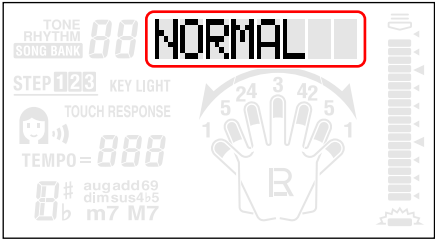
Mode Switch	LCD
<p><b>FINGERED</b> POWER/MODE</p>  <ul style="list-style-type: none"> <li>■ FINGERED</li> <li>■ CASIO CHORD</li> <li>■ NORMAL</li> </ul>	
<p><b>CASIO CHORD</b> POWER/MODE</p>  <ul style="list-style-type: none"> <li>■ FINGERED</li> <li>■ CASIO CHORD</li> <li>■ NORMAL</li> </ul>	
<p><b>NORMAL</b> POWER/MODE</p>  <ul style="list-style-type: none"> <li>■ FINGERED</li> <li>■ CASIO CHORD</li> <li>■ NORMAL</li> </ul>	

## B. BUTTON CHECK

B-1. Press the “0” button to select the “Button Check”.

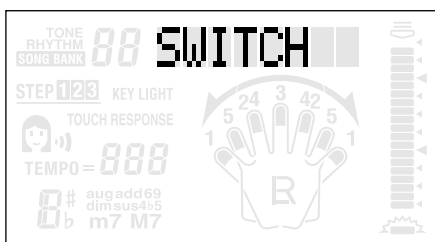

B-2. Press the keys in the order of the numbers indicated in the illustration below.

If the button function is OK:

The confirmation chord sounds, and the button number and “OK” appear on the LCD.

If a button function is not operating properly or a button is pressed in a wrong order:

The error tone sounds, and the button number and “NG” appear on the LCD.

**NOTE:** You cannot cancel this check procedure mid-way.

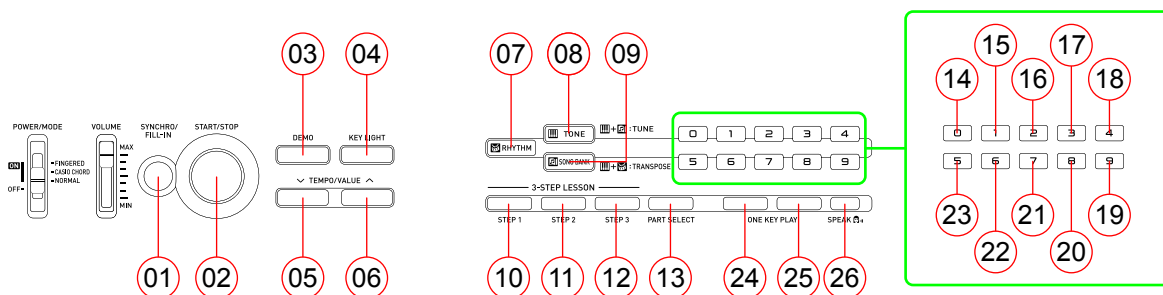

B-3. When the “SPEAK” button is pressed at the end, the confirmation chord sounds and “SWITCHOK” appears on the LCD.

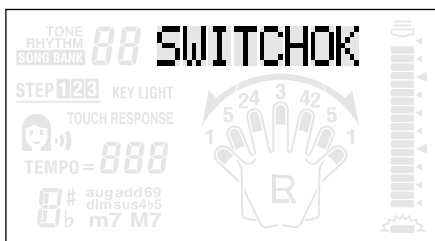

## C. ROM VERSION CHECK

C-1. Press the “1” button to perform the “ROM Version Check”.

The ROM version appears on the LCD.

C-2. Check that the ROM version is “821VR100”.

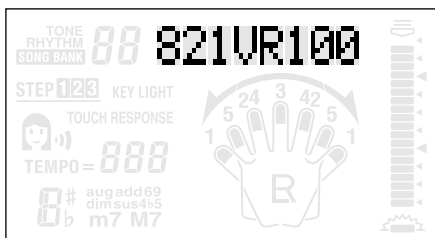

## D. KEYBOARD LED CHECK

- D-1. Press the “TONE” button to perform the “LED Check”.  
Automatically the keyboard LEDs are lit.

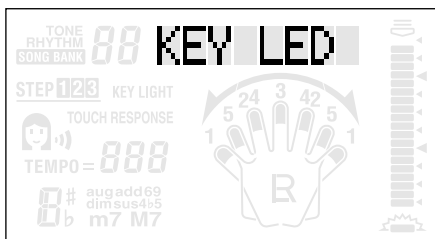

Check the following points.

- The confirmation chords sound and the LEDs are lit in the order indicated in the illustration below.
- There should be no key of which LED brightness is too bright or too faint.

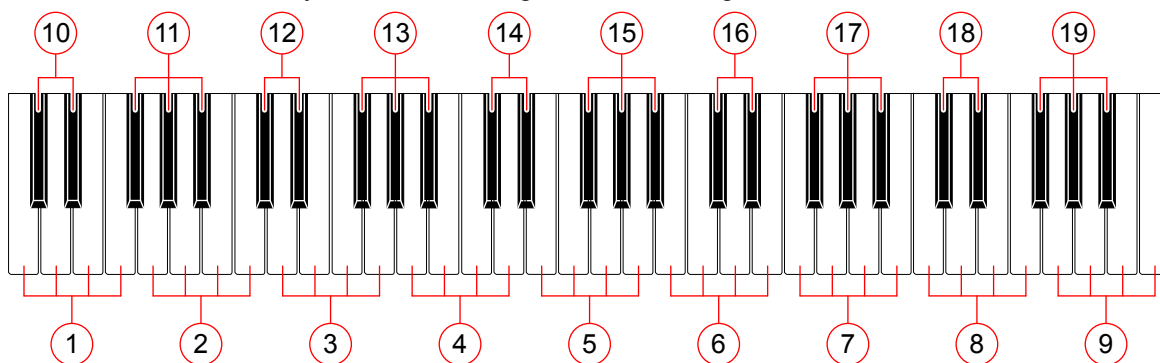

## E. LCD CHECK

- E-1. Press the “STEP 1” button to perform the “LCD Check”.  
The confirmation chord sounds and the display of the LCD is lit.

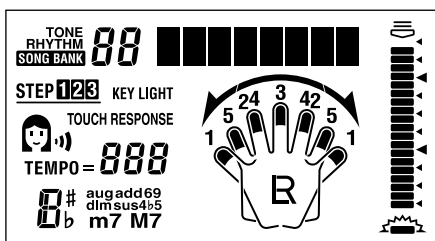

- E-2. Press the “STEP 2” button.  
The confirmation chord sounds and the display of the LCD is turned off.

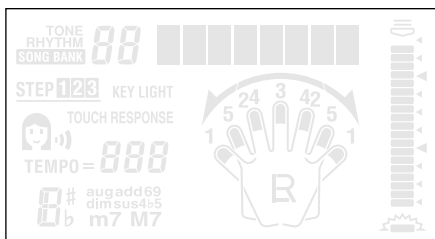

- E-3. Press the “STEP 3” button.  
 The LCD displays automatically change with the confirmation chords in the order indicated in the illustration below.

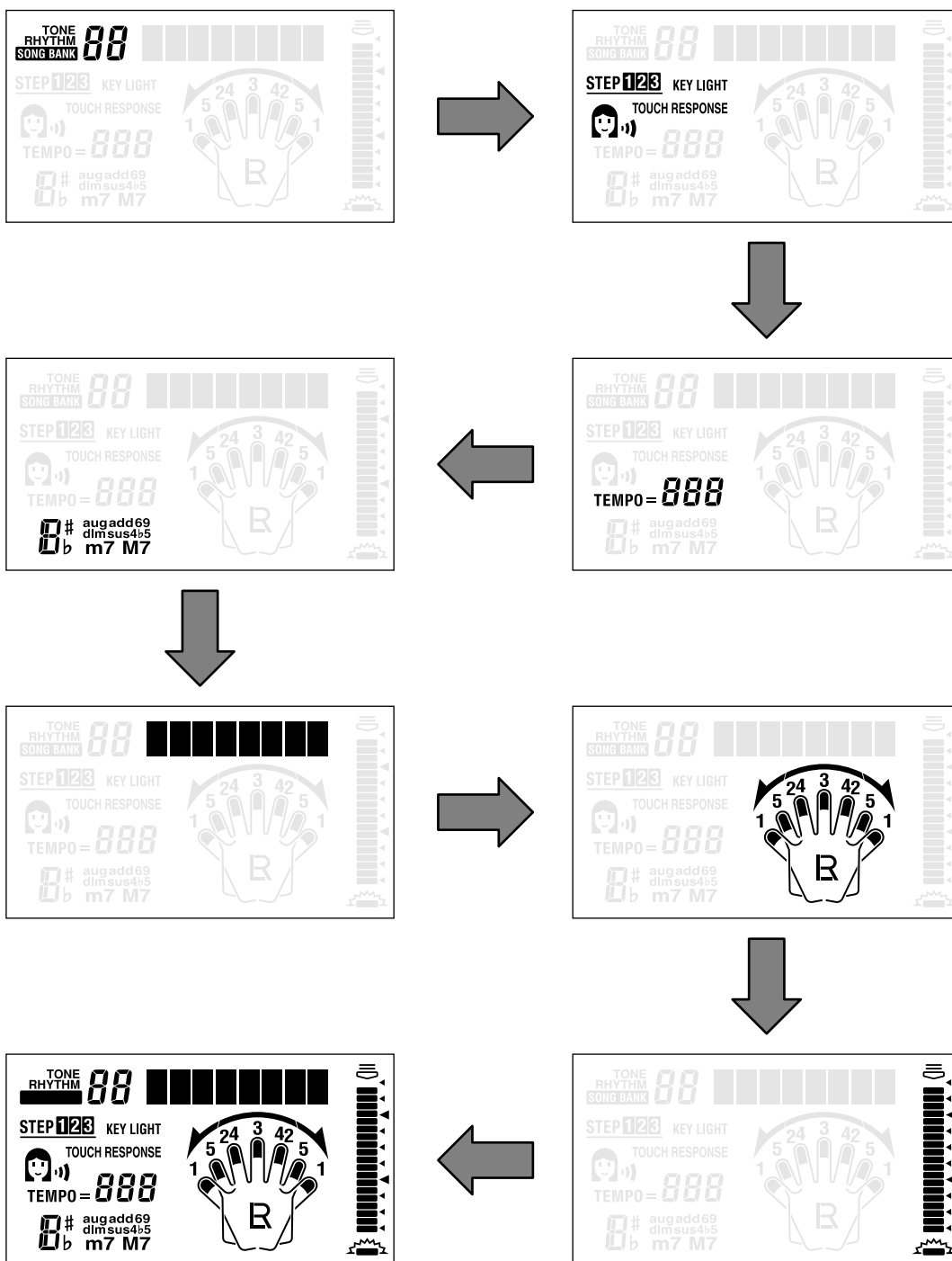

## F. AUTO POWER OFF CHECK

- F-1. Press the “PART SELECT” button to perform the “Auto Power Off Check”.
- F-2. The power supply is turned off and no screen appears on the LCD.
- NOTE:** After checking, be sure to turn the mode switch to “OFF”.

## G. KEY CHECK

---

**NOTE:** Perform the tests with regular power-on state.

G-1. Check the following points by pressing all keys.

- The tones sound correctly by hitting keys.
- The pitch of the sound corresponding to a key is correct.
- Hitting a key does not produce two tones or make sounds twice.
- The stroke and the load of keys are normal.
- The difference in height and the gap between keys are even.

**NOTE:** Press the keys in the order shown in the illustration below.

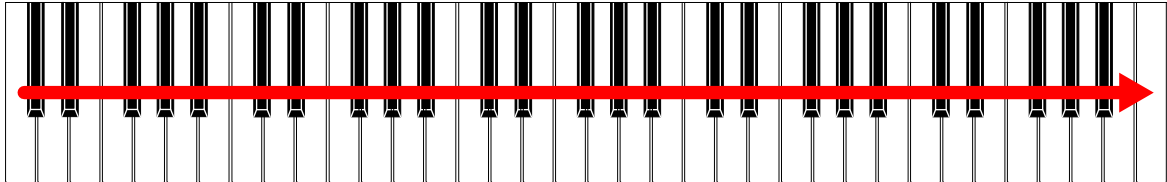

## H. HEADPHONES CHECK

---

**NOTE:** Perform the tests with regular power-on state.

- H-1. Connect the headphones to the PHONES/OUTPUT jack.
- H-2. Press any key and check that you can hear the sound through the headphones.
- H-3. Remove the headphones.
- H-4. Press any key and check that sounds come out from the speakers.

# EXPLODED VIEW

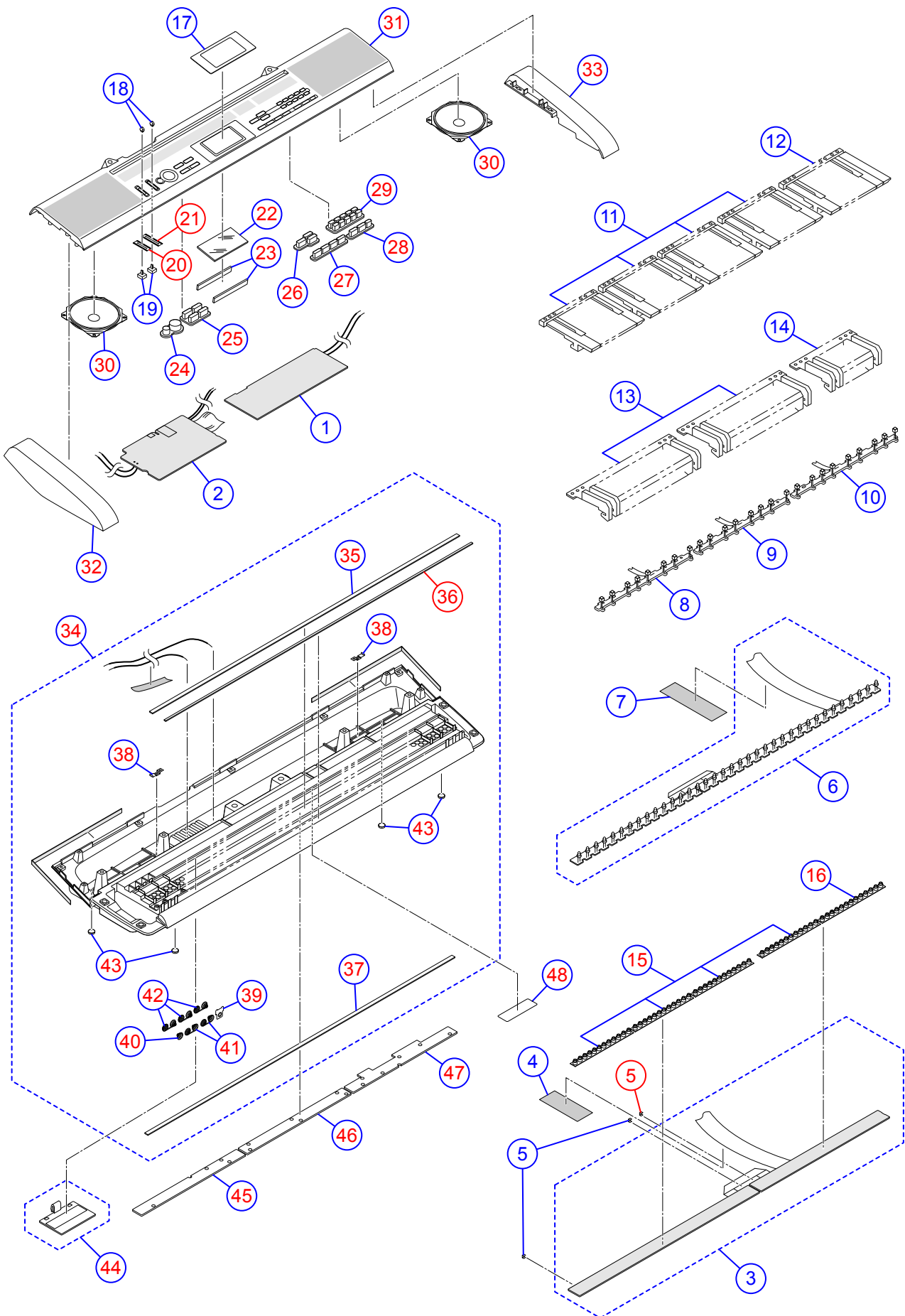



# PARTS LIST

## LK-120

Notes:

1. Prices and specifications are subject to change without prior notice.
2. Refer to the latest “Parts Price Code” at “PARTS FINDER” on the Casio Service WEB site (<https://www.servicecasio.com>).
3. As for spare parts order and supply, refer to the “GUIDEBOOK for Spare parts Supply”, published separately.
4. The numbers in item column correspond to the same numbers in drawing.

- 1: LK-120\_DI
- 2: LK-120\_EU
- 3: LK-120\_UK
- 4: LK-120\_US

N	Item	Code No.	Parts Name	Specification	Q'ty				Price Code	R	Remarks
					1	2	3	4			
<b>Main PCB (MDA1)</b>											
N	1	10368210	PCB ASSY/MDA1	TK-RJM510419*001	1	1	1	1		B	Main PCB
N	CN8	10178633	WIRE/for speaker	1007TASC24100B4040	1	1	1	1		X	Blue (+)
N	CN9	10366747	WIRE/for speaker	1007TASC24100W4040	1	1	1	1		X	White (-)
	VR1	69304870	VARIABLE RESISTOR	EVND8AA03B53	1	1	1	1		X	LCD Contrast Volume
	D1-D8	10276977	DIODE	L1SS400T1G	8	8	8	8		X	
	IC4	10240586	IC	XC6109N40ANR	1	1	1	1		X	
N	IC1	10363062	LSI	ML6756B32GAZ03A114	1	1	1	1		C	
	IC3	10222381	LSI	ST7066U-0A-QG	1	1	1	1		C	
	IC2	10159709	LSI	UPD65881GK-1019ETA	1	1	1	1		C	
	Q9	69300298	TRANSISTOR	2SC4081T106R	1	1	1	1		X	
	Q5-Q8	10209018	TRANSISTOR	KTA501U-GR-RTK/P	4	4	4	4		X	
	Q1-Q4	10207076	TRANSISTOR	KTC601U-GR-RTK/P	4	4	4	4		X	
	TH1	10138692	THERMISTOR	NCP18XH103J03RB	1	1	1	1		X	
	X1	10070555	RESONATOR	CSTCW20M0X51-R0	1	1	1	1		X	
<b>Power Amp PCB (PSA1)</b>											
N	2	10368211	PCB ASSY/PSA1	TK-RJM510421*001	1	1	1	1		C	PSA1 PCB
	CN205,CN206	10178633	WIRE/for speaker	1007TASC24100B4040	2	2	2	2		X	Blue (+)
	CN204,CN207	10366747	WIRE/for speaker	1007TASC24100W4040	2	2	2	2		X	White (-)
	J201	35015103	JACK	HEC3110-01-010	1	1	1	1		B	DC Jack
	J202	10305218	JACK	JY-6316B*01-070	1	1	1	1		C	Phones/Output Jack
	IC201	10300598	IC	TA8227APL-D12-H-T	1	1	1	1		X	
	L202	10231919	COIL	RB53-856396NP	1	1	1	1		X	
	L201	10231920	COIL	RB53-856397NP	1	1	1	1		X	
	D203-D204	10261170	DIODE	SRT14-A2	2	2	2	2		X	
	D206-D207	79114195	DIODE	UDZSTE-175.6B	2	2	2	2		X	
	D201-D202	10371167	DIODE	L1SS355T1G	2	2	2	2		X	
	Q204	10206676	TRANSISTOR	KTC2026-Y-U/P	1	1	1	1		X	
	Q201	69300298	TRANSISTOR	2SC4081T106R	1	1	1	1		X	
	Q202	10217742	TRANSISTOR	KTA1270-Y-AT/P	1	1	1	1		X	
	Q203	10209015	TRANSISTOR	KTD863-GR-AT/P	1	1	1	1		X	
<b>Keyboard PCB</b>											
	3	10368208	PCB ASSY/KYA	TK-RJM508609*002	1	1	1	1		C	KYA PCB
	D801-D830,D832	10301580	DIODE	LM1MA142WAT1G	31	31	31	31		X	
	4	10078918	SPONGE/40X100	M440962-001V01	1	1	1	1		X	
	5	69268840	FABRIC TAPE/4X10	M440684-1	3	3	3	3		X	
N	6	10368212	PCB ASSY/LDA	TK-RJM510423*001	1	1	1	1		C	LDA PCB
	D501-D536	10302396	LED	1154SURDKB5/7.5-90	36	36	36	36		X	
	7	10263729	SPONGE/43X180	M441123-001V01	1	1	1	1		X	
	8	10310713	PCB ASSY/LD3M	TK-M240428*011	1	1	1	1		C	LD3M PCB
	LED451-LED458	10302396	LED	1154SURDKB5/7.5-90	8	8	8	8		X	
	9	10310714	PCB ASSY/LD4M	TK-M240429*011	1	1	1	1		C	LD4M PCB
	LED459-LED466	10302396	LED	1154SURDKB5/7.5-90	8	8	8	8		X	
	10	10310715	PCB ASSY/LD5M	TK-M240430*011	1	1	1	1		C	LD5M PCB
	LED467-LED475	10302396	LED	1154SURDKB5/7.5-90	9	9	9	9		X	
<b>Keyboard unit</b>											
	11	10304700	WHITE KEY/CB	TK-RJM507243*003	4	4	4	4		C	
	12	10304699	WHITE KEY/CS	TK-RJM507244*003	1	1	1	1		C	
	13	10301442	BLACK KEY/10P	RJM506595-009V02	2	2	2	2		C	
	14	10301443	BLACK KEY/5P	RJM506595-010V02	1	1	1	1		C	
	15	10163902	RUBBER CONTACT/CB	RJM503854-001V01	4	4	4	4		B	
	16	10163903	RUBBER CONTACT/CS	RJM503855-001V01	1	1	1	1		B	

- 1: LK-120\_DI  
 2: LK-120\_EU  
 3: LK-120\_UK  
 4: LK-120\_US

N	Item	Code No.	Parts Name	Specification	Q'ty				Price Code	R	Remarks
					1	2	3	4			
<b>Panel unit</b>											
N	17	10371166	PLATE/DISPLAY	RJM510316-003V02	1	1	1	1		X	
	18	10301435	KNOB	RJM503803-009V01	2	2	2	2		X	
	19	69095890	CONTACT/SLIDE SWITCH	CSB-12D	2	2	2	2		X	
N	20	10417026	FABRIC TAPE	RJM511849-001V01	1	1	1	1		X	
N	21	10417025	FABRIC TAPE	RJM511833-001V01	1	1	1	1		X	
	22	10272509	LCD	SDT-M4396-RP-0	1	1	1	1		X	
	23	10366853	RUBBER CONNECTOR	RJM510317-001V01	2	2	2	2		X	
N	24	10366689	RUBBER KEY/A	RJM510262-002V01	1	1	1	1		X	
N	25	10366690	RUBBER KEY/B	RJM510264-002V01	1	1	1	1		X	
N	26	10366692	RUBBER KEY/C	RJM510282-002V01	1	1	1	1		X	
N	27	10366693	RUBBER KEY/D	RJM510283-002V01	1	1	1	1		X	
N	28	10366694	RUBBER KEY/E	RJM510284-002V01	1	1	1	1		X	
N	29	10366695	RUBBER KEY/F	RJM510285-001V01	1	1	1	1		X	
	30	10264808	SPEAKER	C10J01A	2	2	2	2		X	
N	31	10366691	PANEL	RJM510265-003V01	1	1	1	1		X	
	32	10366841	SIDE PANEL/LEFT	RJM510267-001V01	1	1	1	1		X	
	33	10366842	SIDE PANEL/RIGHT	RJM510268-001V01	1	1	1	1		X	
<b>Main case unit</b>											
	34	10368209	CASE UNIT/MAIN	TK-RJM510380*001	1	1	1	1		X	
	35	10301471	FELT/LOWER	RJM508593-001V01	1	1	1	1		X	
	36	10317116	FELT/DAMPER/KEYBOARD	RJM509138-001V01	1	1	1	1		X	
	37	10205015	FELT/UPPER	M440342-001V02	1	1	1	1		X	
	38	10284332	BRACKET/for stand	M440866-001V02	2	2	2	2		X	
	39	69271080	BATTERY SPRING/(+)	M440112-1	1	1	1	1		X	
	40	10274835	BATTERY SPRING/(-)	M440002-001V02	1	1	1	1		X	
	41	69271060	BATTERY SPRING-470A	M440676-1	2	2	2	2		X	
	42	69271070	BATTERY SPRING-470B	M440677-1	3	3	3	3		X	
	43	69226920	RUBBER FOOT	M41361-6	4	4	4	4		X	
	44	10243428	COVER ASSY/BATTERY	TK-M340884*020	1	1	1	1		X	
	45	10329837	LOWER COVER-A	RJM508655-001V03	1	1	1	1		X	
	46	10329838	LOWER COVER-B	RJM508656-001V03	1	1	1	1		X	
	47	10329839	LOWER COVER-C	RJM508657-001V03	1	1	1	1		X	
N	48	10369139	RATING LABEL	RJM504373-033V02	1	1	1	1		X	
<b>Accessories</b>											
	-	10366857	MUSIC STAND	RJM510426-001V01	1	1	1	1		C	

# SCHEMATIC DIAGRAMS

## Main PCB: M821-MDA1

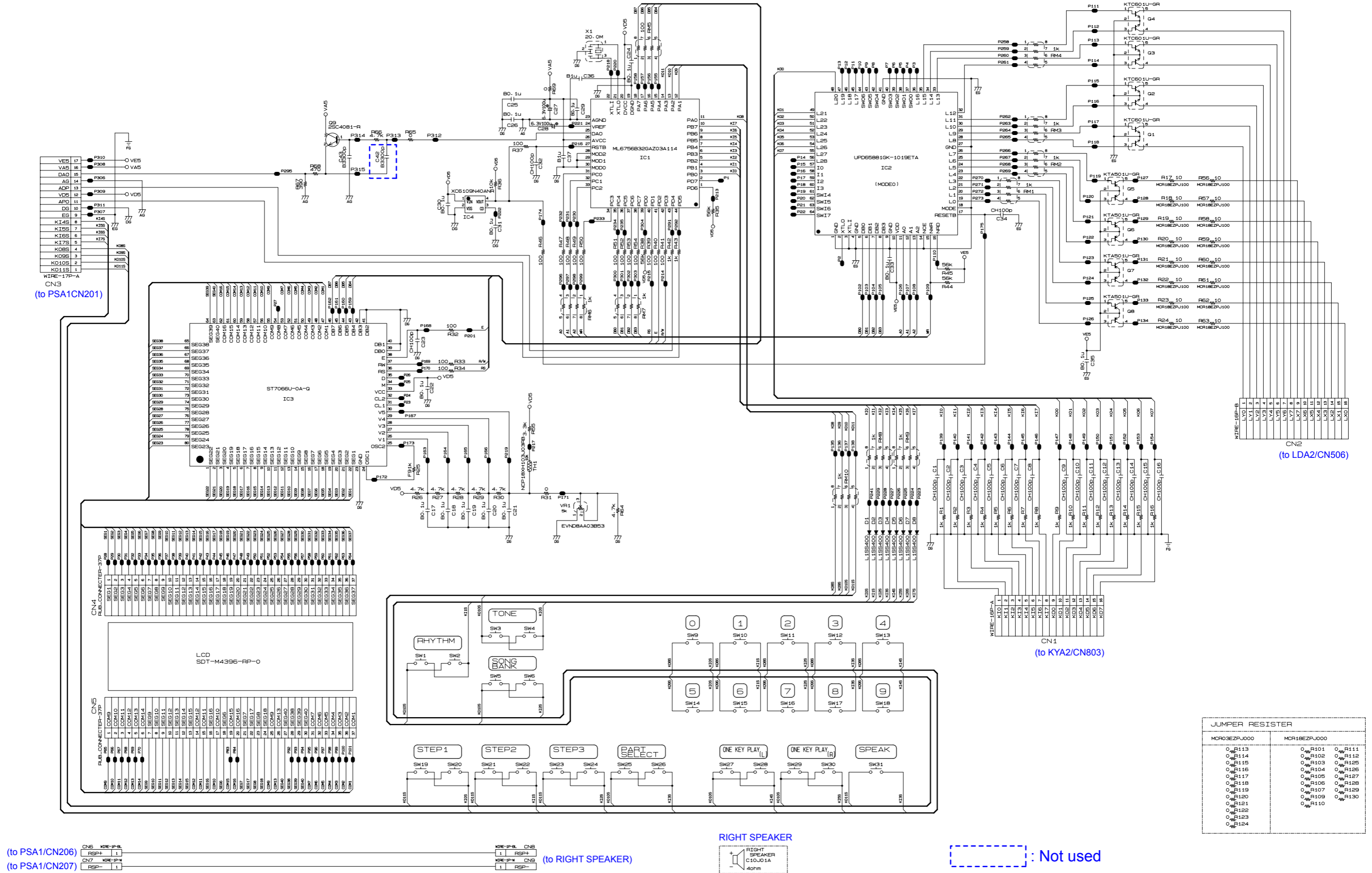

JUMPER RESISTOR	
MCR03E2P-000	MCR18E2P-000
○ <sub>W</sub> R113	○ <sub>W</sub> R101
○ <sub>W</sub> R114	○ <sub>W</sub> R102
○ <sub>W</sub> R115	○ <sub>W</sub> R103
○ <sub>W</sub> R116	○ <sub>W</sub> R104
○ <sub>W</sub> R117	○ <sub>W</sub> R105
○ <sub>W</sub> R118	○ <sub>W</sub> R106
○ <sub>W</sub> R119	○ <sub>W</sub> R107
○ <sub>W</sub> R120	○ <sub>W</sub> R108
○ <sub>W</sub> R121	○ <sub>W</sub> R109
○ <sub>W</sub> R122	○ <sub>W</sub> R110
○ <sub>W</sub> R123	
○ <sub>W</sub> R124	

(to PSA1/CN206)  
(to PSA1/CN207)

(to RIGHT SPEAKER)



: Not used

Sub PCB: M820-PSA1

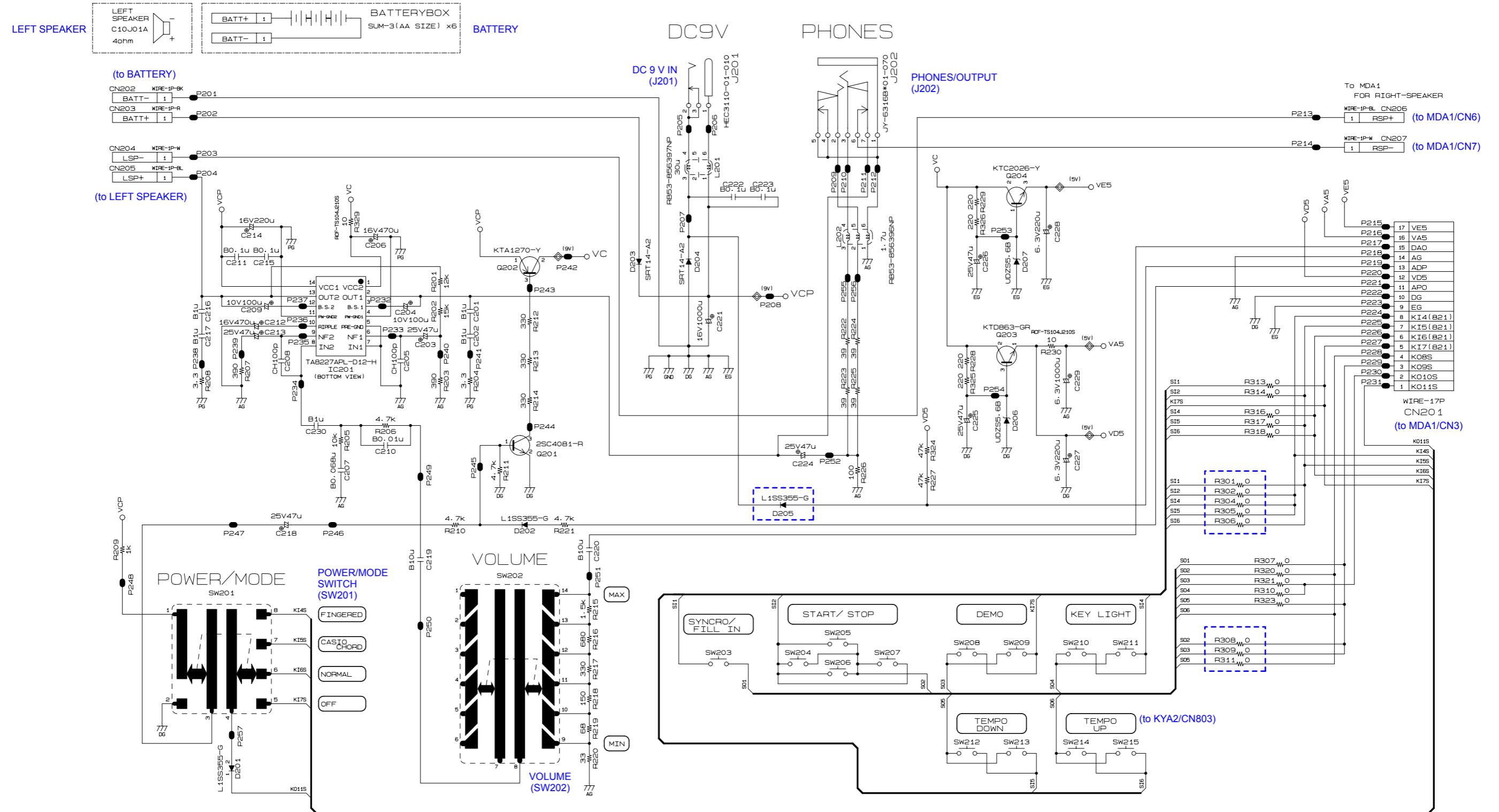

JUMPER RESISTOR

0 <sub>W</sub> R401	0 <sub>W</sub> R411	0 <sub>W</sub> R421	0 <sub>W</sub> R431	0 <sub>W</sub> R441
0 <sub>W</sub> R402	0 <sub>W</sub> R412	0 <sub>W</sub> R422	0 <sub>W</sub> R432	0 <sub>W</sub> R442
0 <sub>W</sub> R403	0 <sub>W</sub> R413	0 <sub>W</sub> R423	0 <sub>W</sub> R433	0 <sub>W</sub> R443
0 <sub>W</sub> R406	0 <sub>W</sub> R415	0 <sub>W</sub> R424	0 <sub>W</sub> R434	0 <sub>W</sub> R445
0 <sub>W</sub> R408	0 <sub>W</sub> R416	0 <sub>W</sub> R425	0 <sub>W</sub> R440	0 <sub>W</sub> R447
0 <sub>W</sub> R409	0 <sub>W</sub> R417	0 <sub>W</sub> R426		0 <sub>W</sub> R448
0 <sub>W</sub> R410	0 <sub>W</sub> R418	0 <sub>W</sub> R427		0 <sub>W</sub> R449
	0 <sub>W</sub> R419	0 <sub>W</sub> R428		0 <sub>W</sub> R450
	0 <sub>W</sub> R420	0 <sub>W</sub> R429		0 <sub>W</sub> R451

   : Not used

Keyboard LED PCB: M821-LDA1

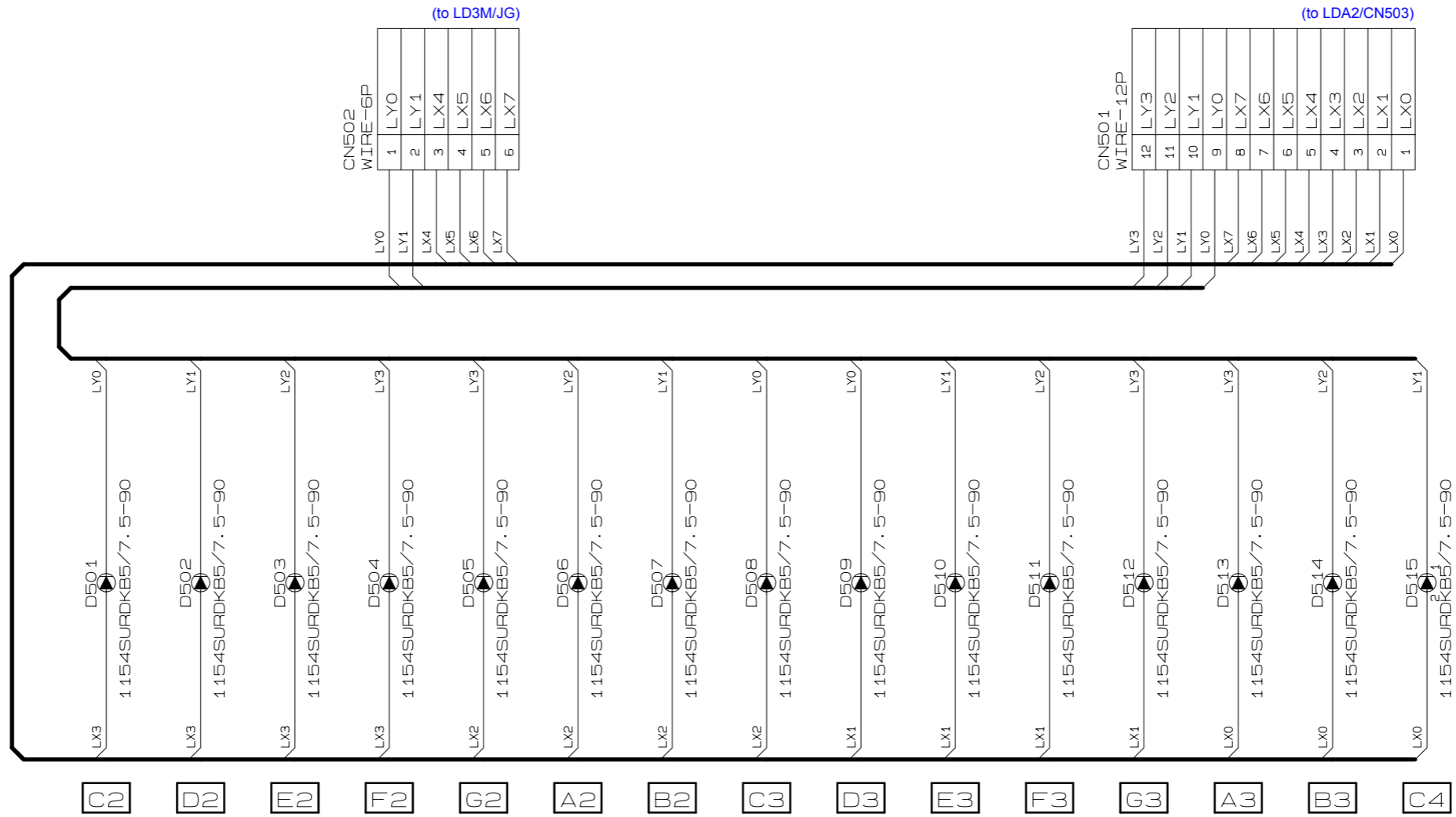

Keyboard LED PCB: M821-LDA2

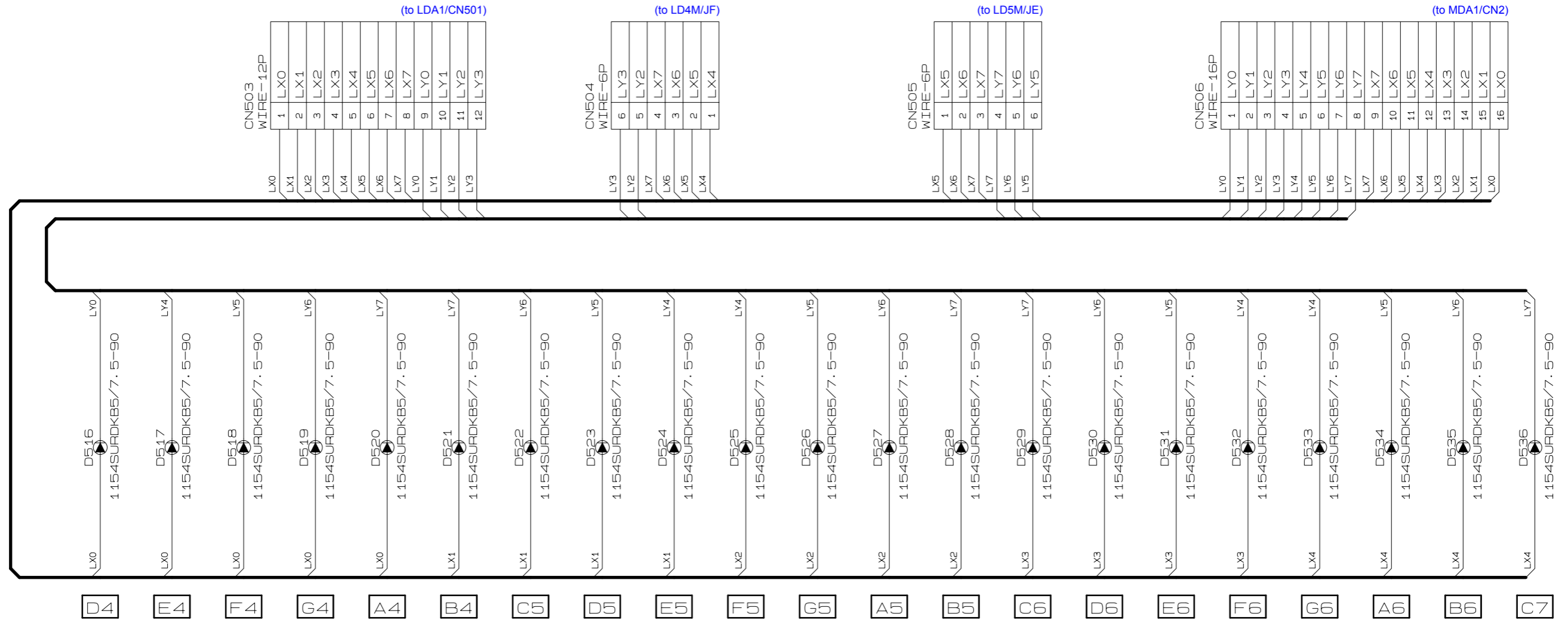

Keyboard LED PCB: CSM446-LD3M/LD4M/LD5M

CSM446-LD3M

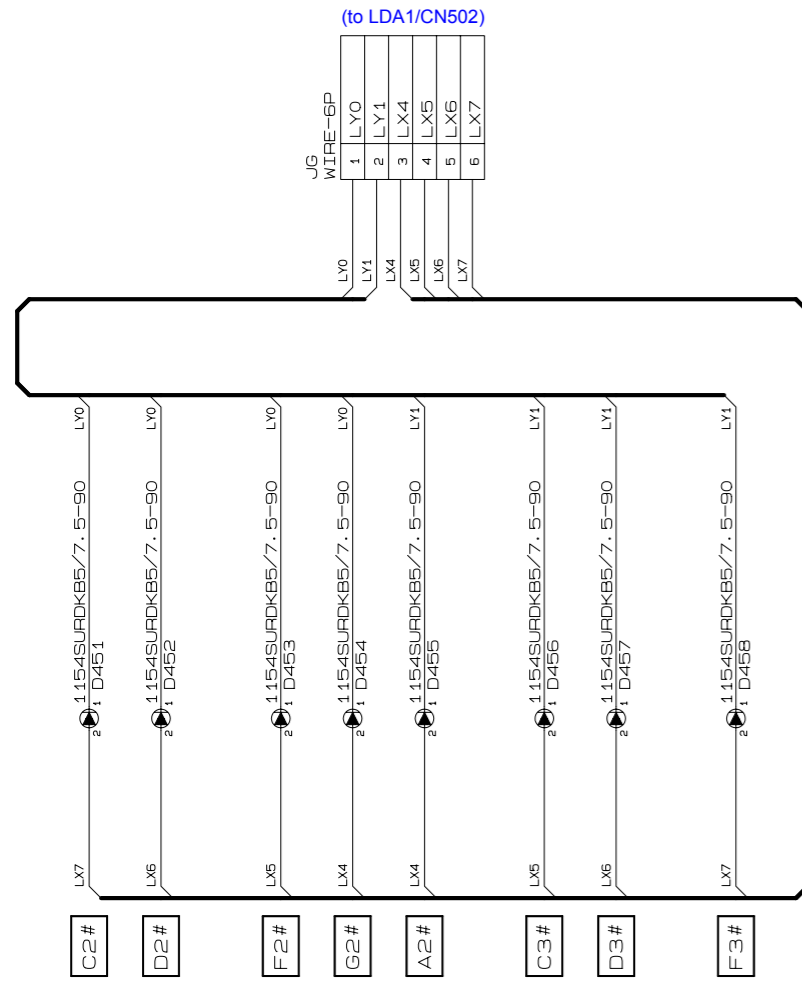

CSM446-LD4M

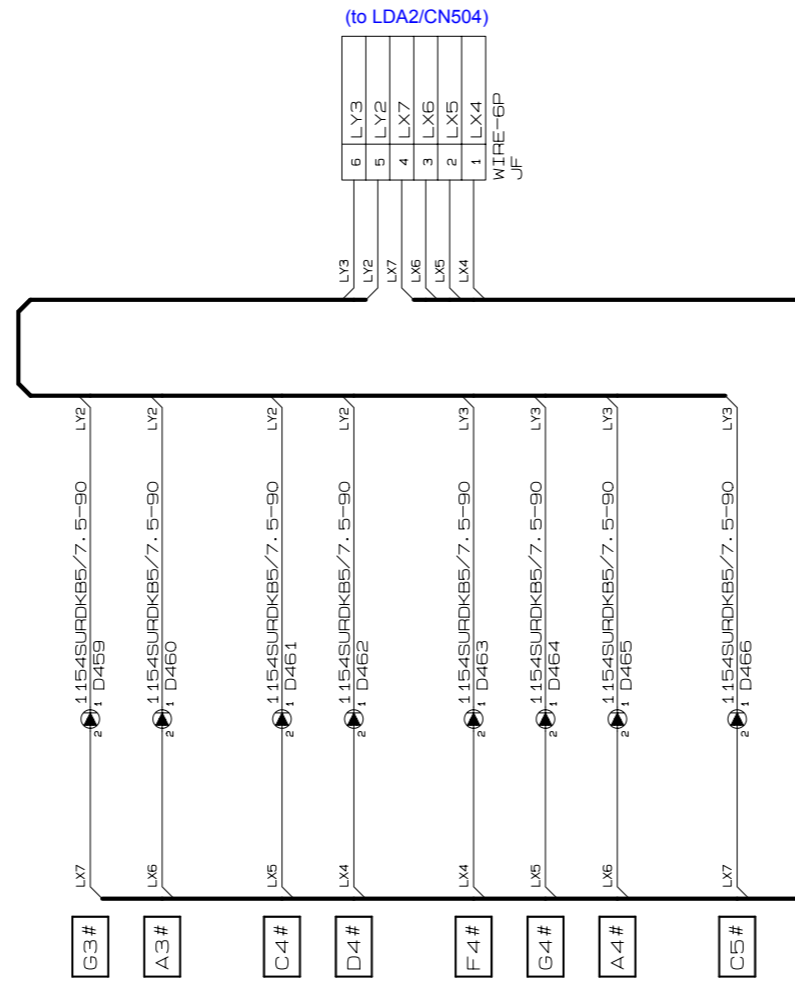

CSM446-LD5M

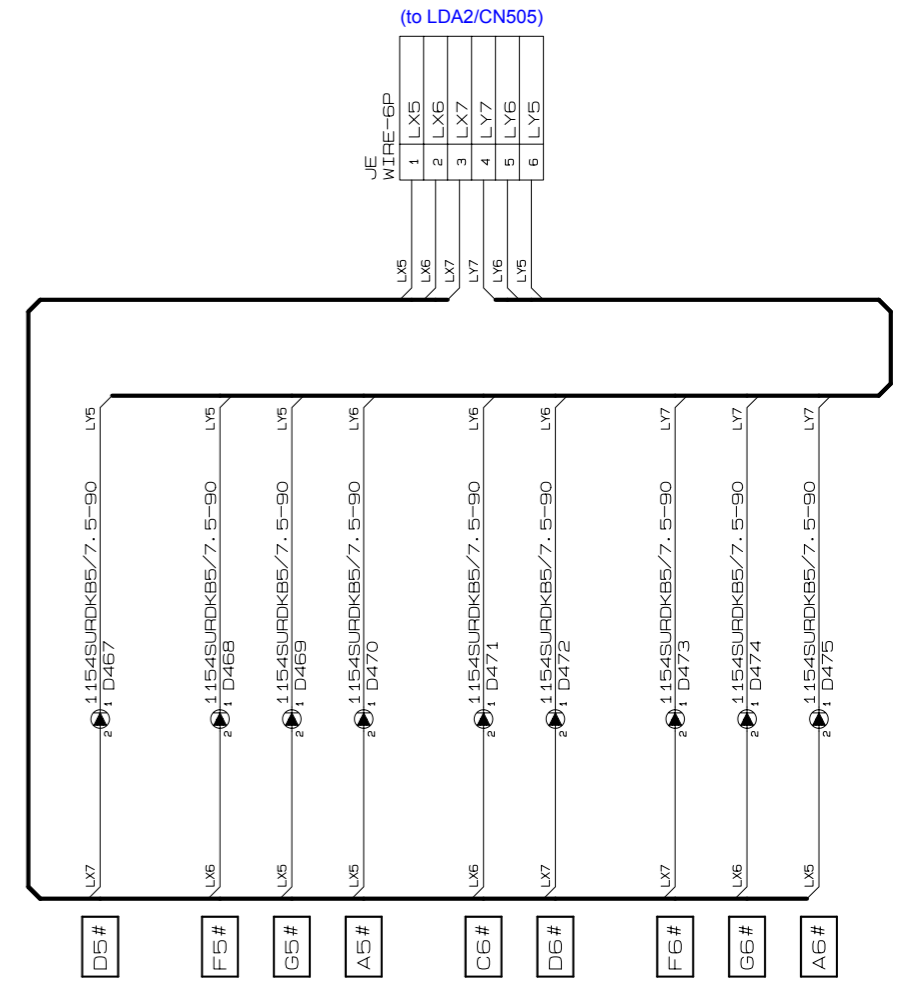



Keyboard PCB: M800-KYA1/KYA2

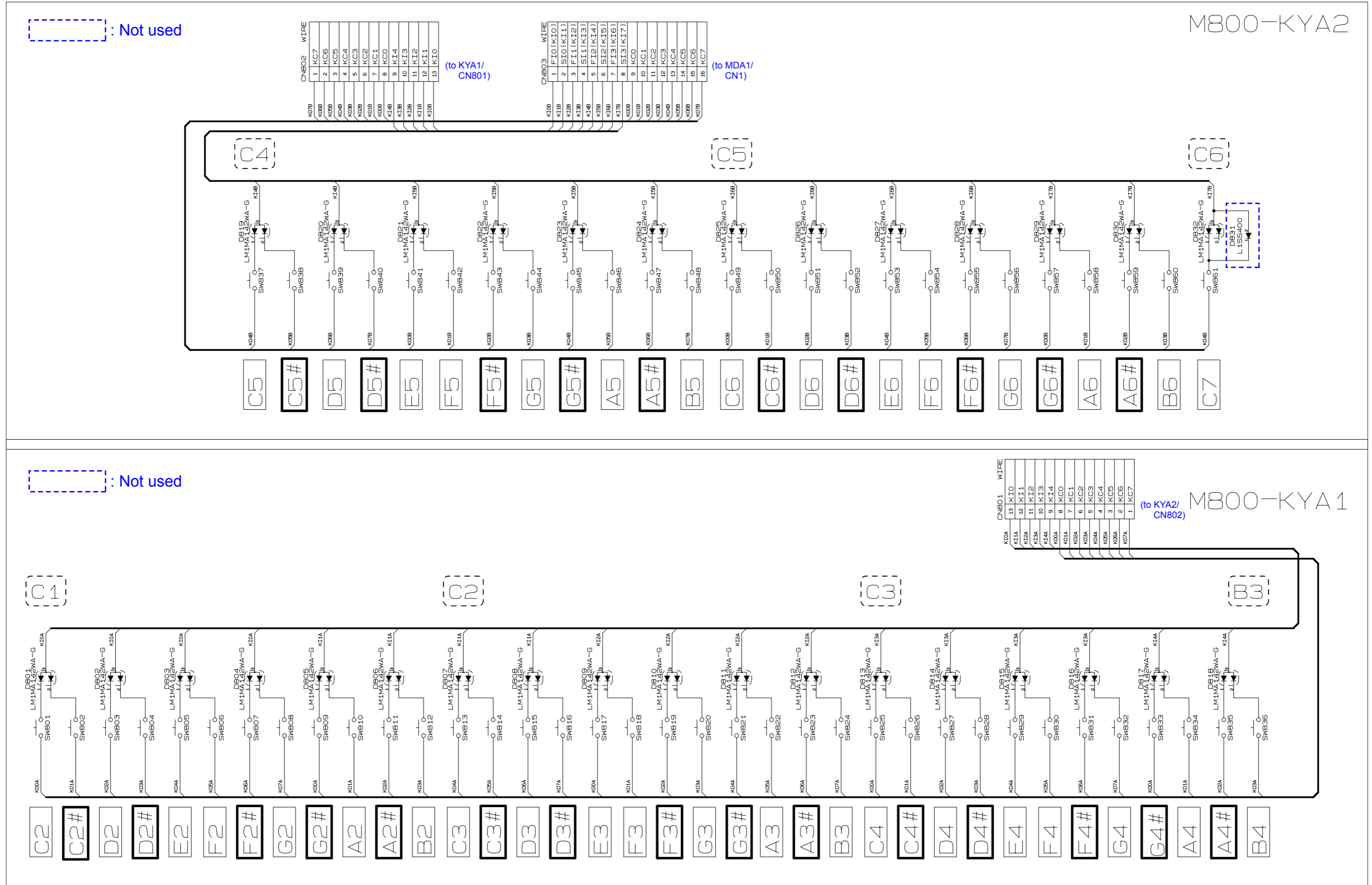

Ver. 1 : Dec. 2011

- Correction of the PARTS LIST (P24)

Ver. 2 : Jan. 2012

- Correction of the EXPLODED VIEW (P22)
- Correction of the PARTS LIST (P24 and P25)

**CASIO COMPUTER CO.,LTD.**

Overseas Service Division

6-2, Hon-machi 1-Chome  
Shibuya-ku, Tokyo 151-8543, Japan