

CASIO®

Service Manual

(with price)

PK-5



ELECTRONIC KEYBOARD

CONTENTS

Specifications	1
Block Diagram	2
Circuit Description	3
Troubleshooting	4
PCB View and Major Waveforms	5
Schematic Diagrams	6
IC Lead Identification	7
Exploded Veiw	8
Parts List	9

SPECIFICATIONS

General

Number of Keys:	32
Polyphonic:	2-note
Preset Tones:	16
Auto-Rhythms:	19; Rock 1~2, 16 Beat 1~2, Disco 1~3, Pops 1~3, Slow Rock, Swing March, Reggae, Tango, Samba, Bossa Nova, Beguine, Waltz
Accompaniment Patterns:	13; Rock, Pops, Funk, Slow Rock, Latin, Jungle, Orient, Bagpiper, Fanfare, Child's Play, Classical, Computer, New Age
Demonstration Tune:	Classical Medley
Built-In Speaker:	6.5 cm dia. 0.5 W Input Rating: 1 pec.
Power Source:	4 AA size dry batteries Battery life: Approx. 3 hours (SUM-3/R6P) Approx. 6 hours (AM-3/LR6)
Power Consumption:	0.7 W
Dimensions:	41 x 375 x 115 mm (HWD) (1-5/8 x 14-3/4 x 4-1/2 inches) (HWD)
Weight:	0.4 kg (0.9 lbs) excluding batteries

Electrical

Current Drain with 6V DC:	
No Sound Output	35 mA \pm 20%
Maximum Volume	113 mA \pm 20%
with keys C4 and E4 pressed in Flute tone	
Volume: Maximum, Accompaniment: Latin,	
Tempo: Maximum	
Minimum Operating Voltage:	5.0 V

BLOCK DIAGRAM

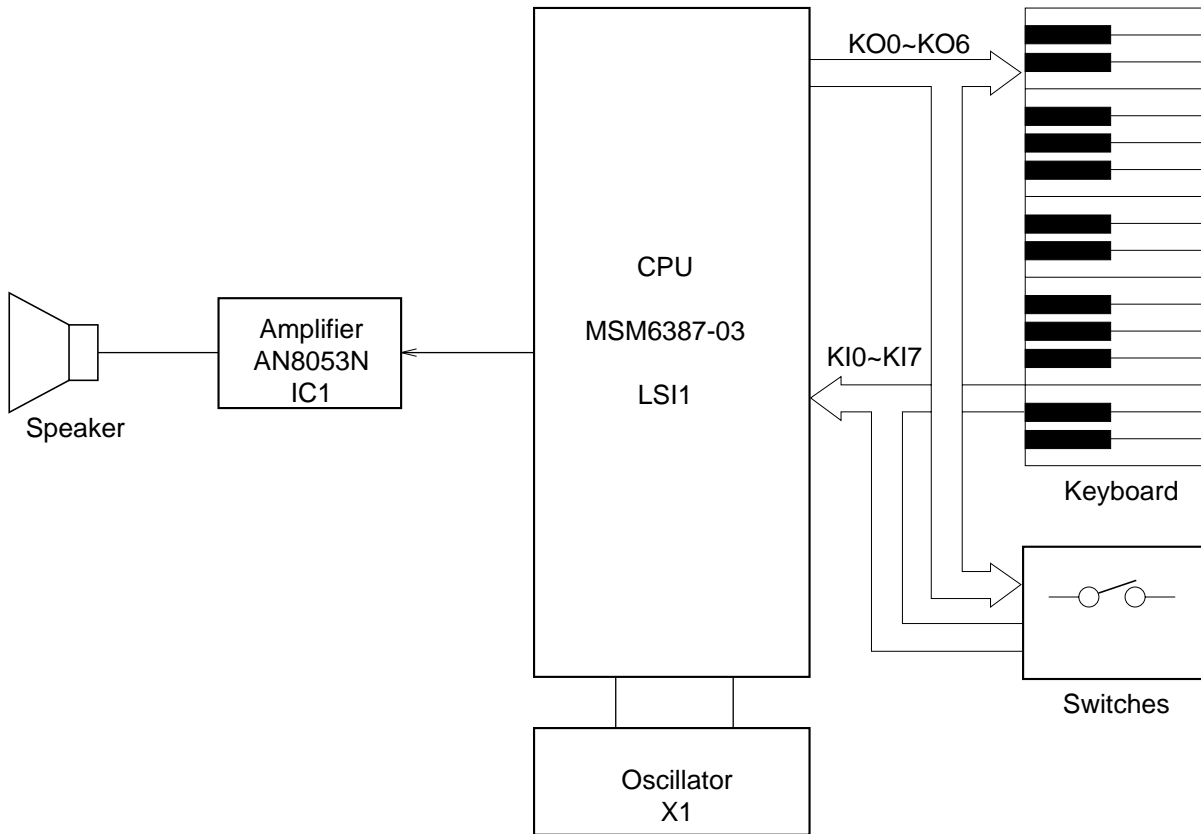

Nomenclature of Keys

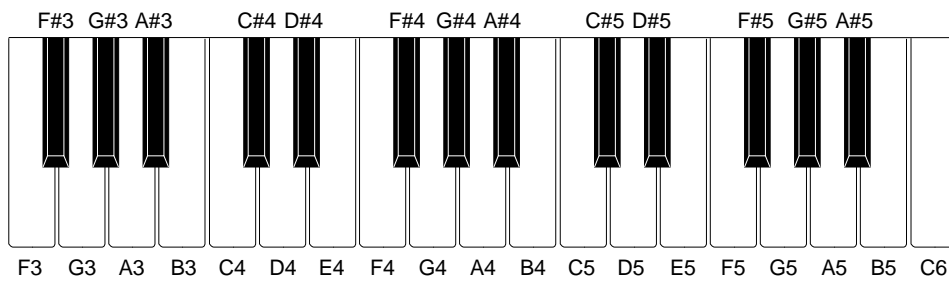

CIRCUIT DESCRIPTION

Key Matrix

	KI0	KI1	KI2	KI3	KI4	KI5	KI6	KI7
KO0	F3	F#3	G3	G#3	A3	A#3	B3	C4
KO1	C#4	D4	D#4	E4	F4	F#4	G4	G#4
KO2	A4	A#4	B4	C5	C#5	D5	D#5	E5
KO3	F5	F#5	G5	G#5	A5	A#5	B5	C6
KO4	Tone 0	Tone 1	Tone 2	Tone 3	Tone 4	Tempo Up	Volume Up	Select
KO5	Tone 5	Tone 6	Tone 7	Tone 8	Tone 9	Stop	Tempo Down	Volume Down
KO6								Demo

CPU (LSI1: MSM6387-03)

Containing a sound data ROM and a DAC (Digital to Analog Converter), the CPU provides sound waveform in accordance with the pressed key and the selected tone.

The following table shows the pin functions of LSI1.

Pin No.	Terminal	In/ Out	Function
1, 2	TEST1, TEST2	—	Not used. Connected to ground.
3	RESET	In	Power ON reset input. On: +6 V Off: 0 V
4	AVDD	In	+5 V source for the built-in DAC
5	OUT	Out	Sound waveform output
6	AGND	In	Ground (0 V) source for the built-in DAC
7	GND	In	Ground (0 V) source
8, 9	COSI, COSO	In/Out	21.725 MHz clock pulse input/output
10	VDD	In	+5 V source
11 ~ 18	KI0 ~ KI7	In	Input terminal from keys and switches
19 ~ 23	KO11 ~ KO7	—	Not used.
24 ~ 30	KO6 ~ KO0	Out	Key and switch scan signal output

Amplifier/Voltage Regulator (IC1: AN8053N)

Consisting of an amplifier and a voltage regulator, AN8053N amplifies the sound signal from the CPU and also provides the CPU +5V source.

The following figure shows the internal block diagram of IC1.

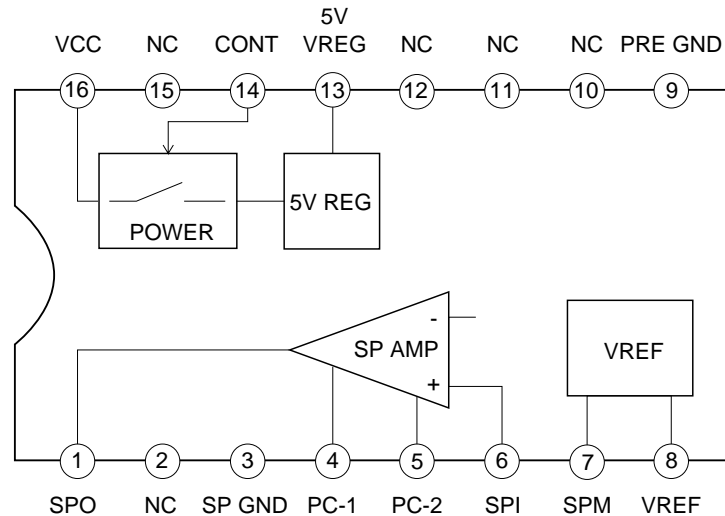

TROUBLESHOOTING

Nature of Trouble	Faulty Block	Checkpoint
No sound at all	Power amp. (IC: AN8053N)	Pin 13 should have +5 V. An amplified waveform should be observed at pin 1.
	Power Switch	Voltage at pin 3 of the CPU should be raised from 0V to +5 V when the power switch is turned on. Switch contact.
	CPU (LSI1: MSM6387-03)	Pins 24 ~ 30 should provide pulses. Pin 5 should provide a sound waveform when a key is pressed.
	Oscillator (X1)	Pins 8 and 9 of the CPU should receive an oscillation signal.
Certain key(s) or switch(es) do(es) not work.	Key or Switch Contact	
	Open Circuit on KO or KI Lines	

PCB VIEW and MAJOR WAVEFORMS

M3205-MA1M PCB

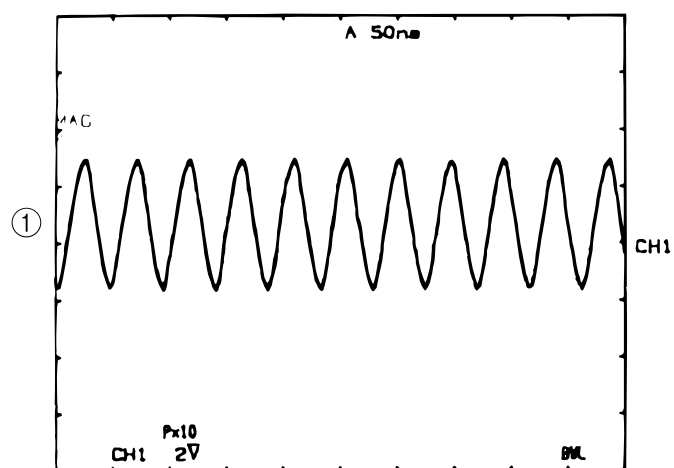
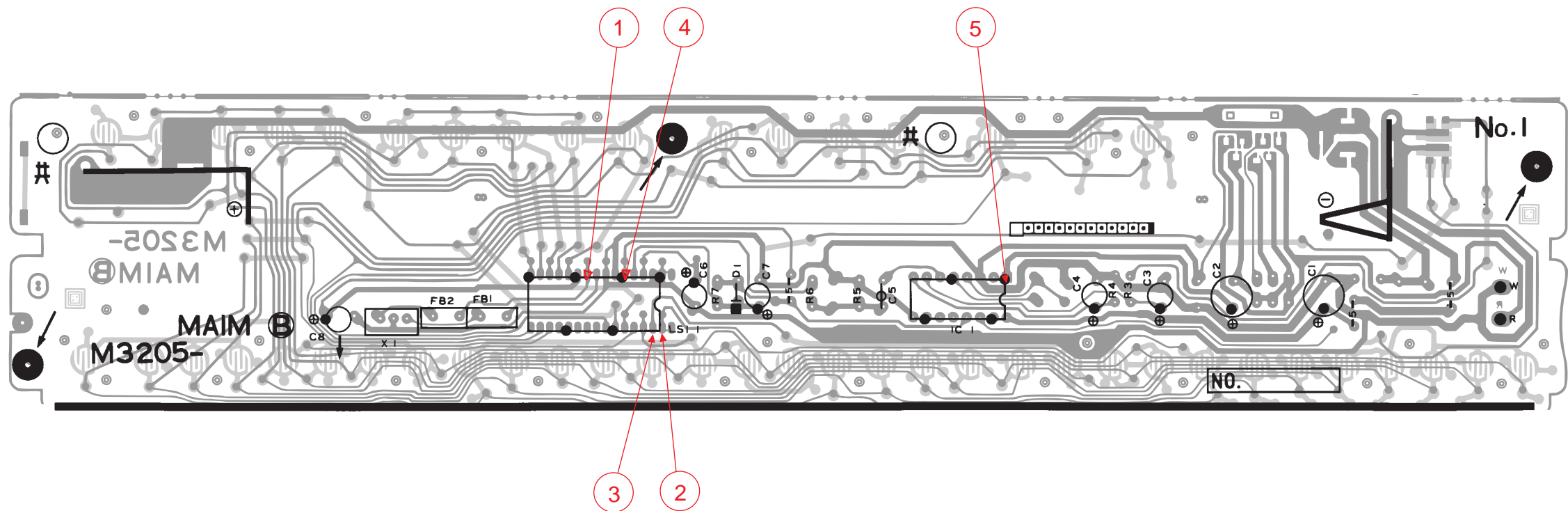

① Clock pulse COSO
MSM6387-03 Pin 9

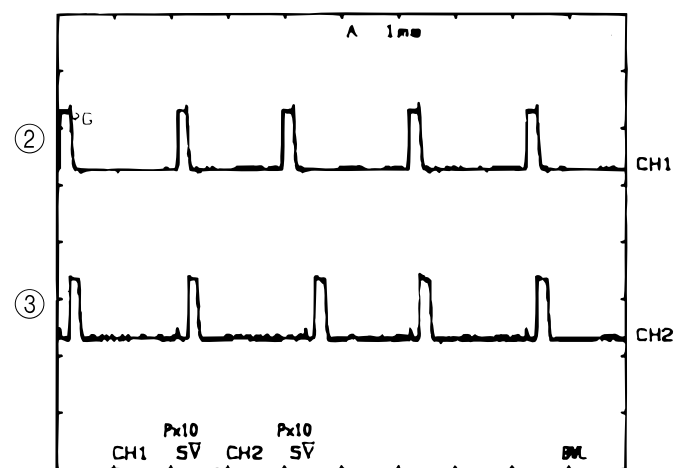

② Key scan signal KO0
MSM6387-03 Pin 30
③ Key scan signal KO1
MSM6387-03 Pin 29

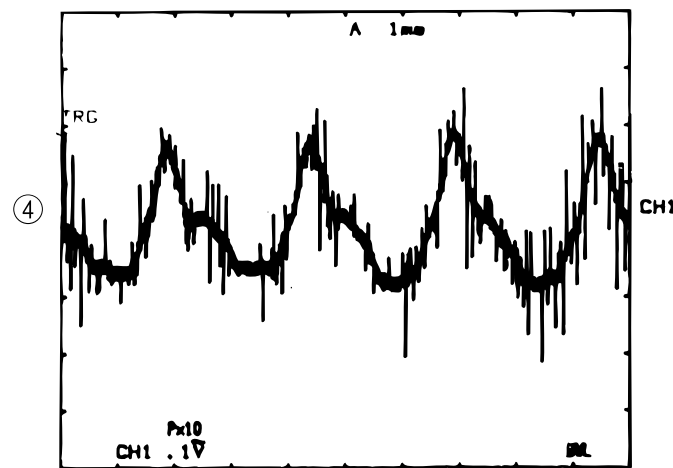

④ Sound output
MSM6387-03 Pin 5
Tone : Piano
Key : G4

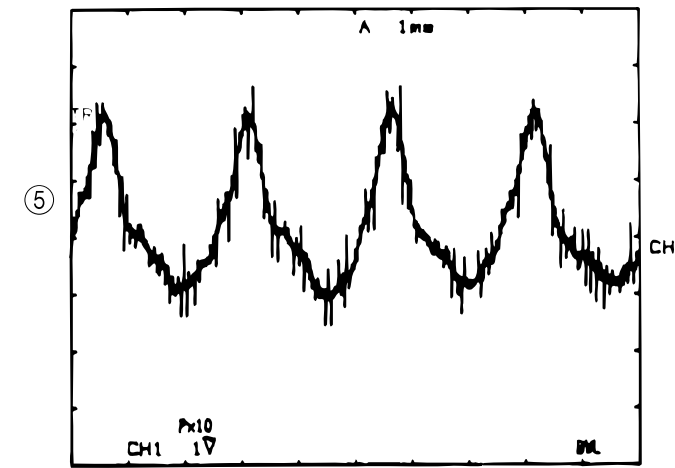

⑤ Power Amp. output
AN8053N Pin 1
Tone : Piano
Key : G4
Volume : Max.

SCHEMATIC DIAGRAM

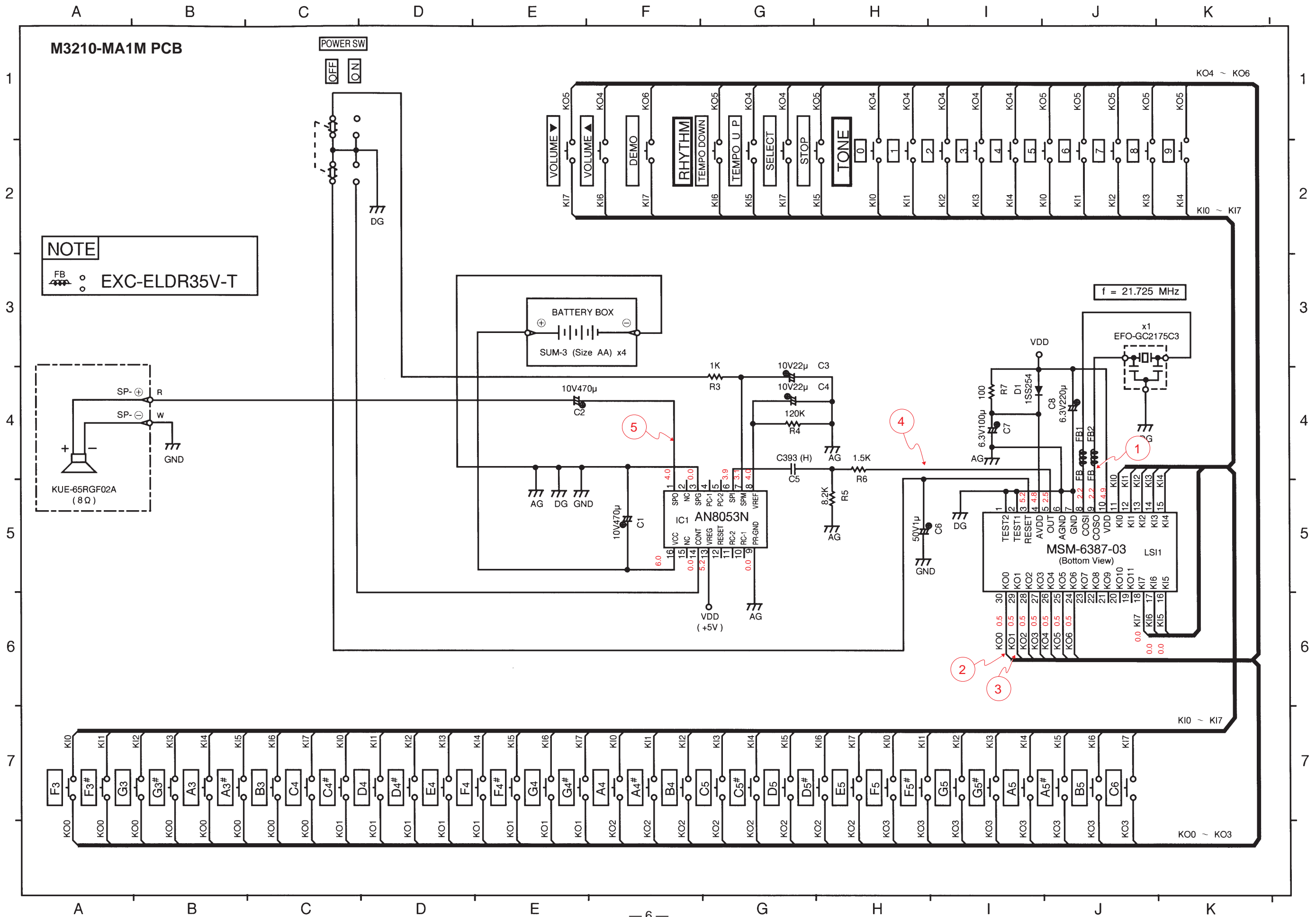

IC LEAD IDENTIFICATION

LSI1: MSM6387-03

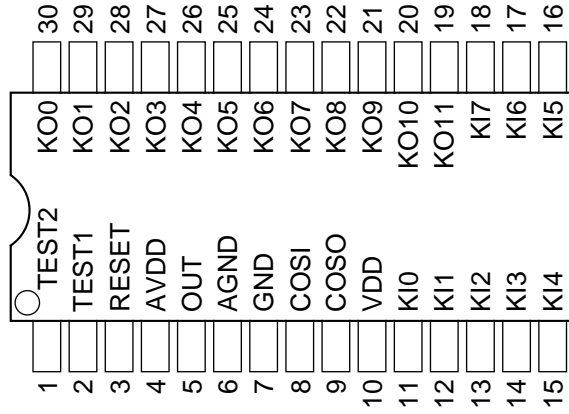

IC1: AN8053N

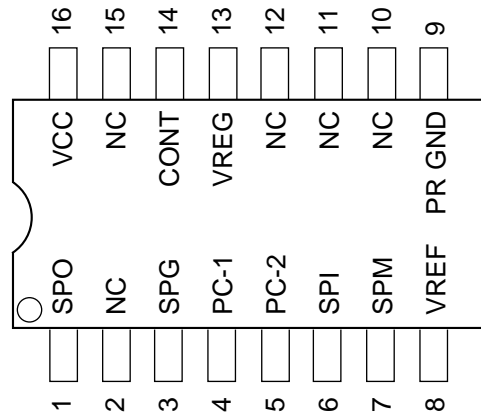

EXPLODED VIEW

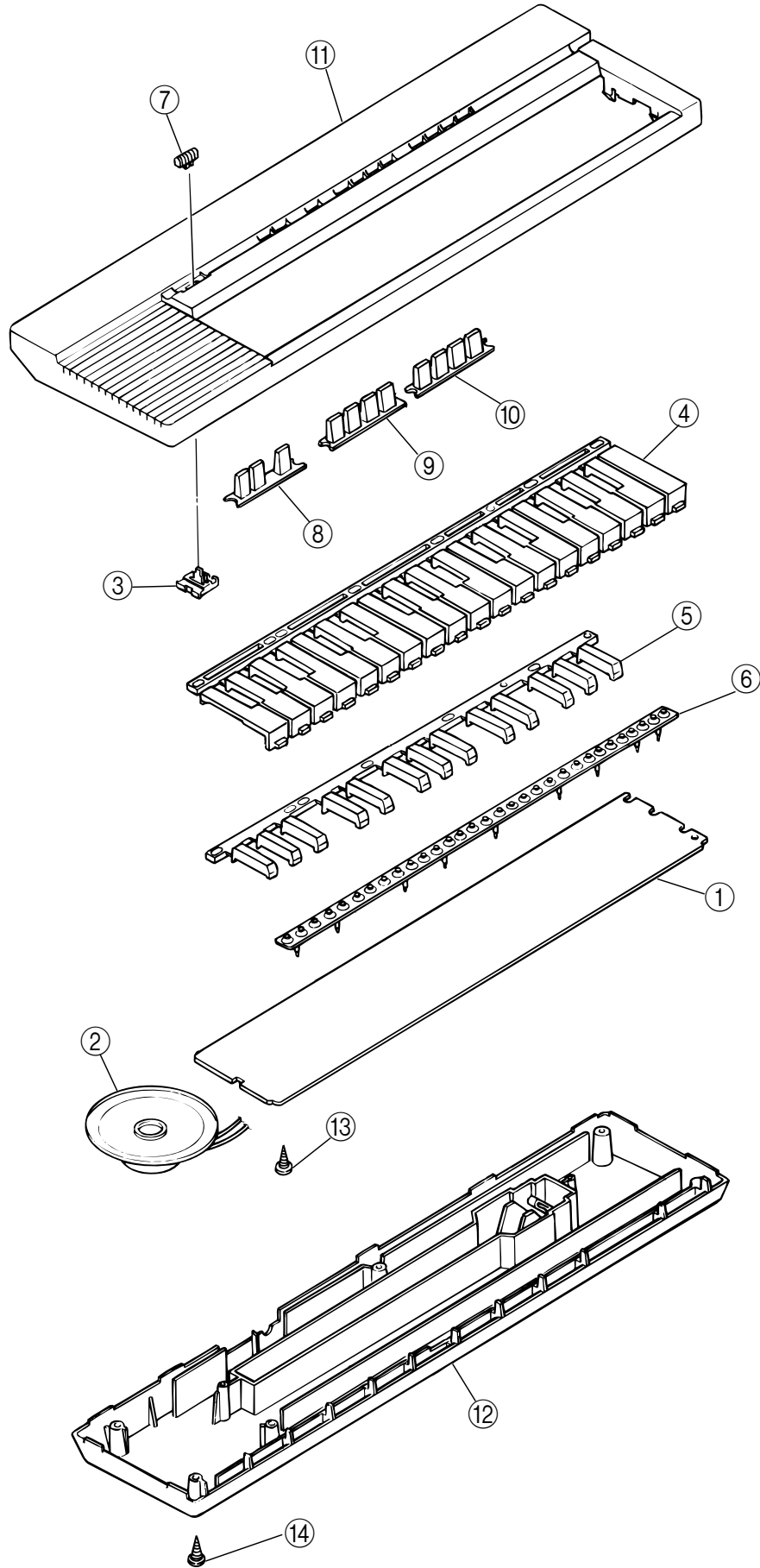

PARTS LIST

PK-5

- Notes:
1. Prices and specifications are subject to change without prior notice.
 2. As for spare parts order and supply, refer to the "GUIDEBOOK for Spare parts Supply", published separately.
 3. The numbers in item column correspond to the same numbers in drawing.

N	Item	Code No.	Parts Name	Specification	Q	M	FOB Japan N.R.Yen Unit Price	R	*
Electrical Parts									
N	C1/2	2807 1531	Electrolytic capacitor	10RE3-470-T2-T	2	20	27	C	A
	C3/4	2807 6392	Electrolytic capacitor	10RE3-22-T2-T	2	20	9	C	A
	C5	2813 1771	Semiconductive capacitor	DD405SR393K16-T	1	10	12	C	A
	C6	2807 6378	Electrolytic capacitor	50RE3-1-T2-T	1	20	9	C	A
	C7	2801 9100	Electrolytic capacitor	6.3RE3-100-T2-T	1	20	12	C	A
	C8	2801 9660	Electrolytic capacitor	6.3RE3-220-T2-T	1	20	15	C	A
	D1	2301 0241	Diode	1SS254T-77-T	1	20	5	C	A
	FB1/2	3035 0266	Ferrite beads	BL02RN2-R62T4-T	2	10	13	C	A
	IC1	2114 3269	IC	AN8053N	1	1	110	A	B
	LS11	2010 8260	LSI	MSM6387-03SS-106	1	1	800	A	I
	R3	2606 1141	Carbon film resistor	R-20-1K-J-T23-T	1	20	2	C	A
	R4	2606 1554	Carbon film resistor	R-20-120K-J-T23-T	1	20	2	C	A
	R5	2606 1239	Carbon film resistor	R-20-8.2K-J-T23-T	1	20	2	C	A
	R6	2606 1274	Carbon film resistor	R-20-1.5K-J-T23-T	1	20	2	C	A
	R7	2606 1169	Carbon film resistor	R-20-100-J-T23-T	1	20	2	C	A
	X1	2590 0742	Ceramic oscillator	EFO-GC2175C3	1	1	65	A	B
			4317 4031	Blank PCB M3205-MA1M	M111705A-1	1	1	120	C
		6917 1762	Battery spring (+)	M410913B-1	1	20	5	B	A
		6921 6211	Battery spring (-)	M412171A-1	1	20	12	B	A
1			PCB ass'y M3205-MA1M	M211679*1	1	1		B	
Mechanical Parts									
N N N	2	3831 0525	Speaker	KUE-65RGF02A	1	1	190	B	C
	3	6909 7380	SL contact 09D	CSB-09D	1	20	26	B	A
	4	6917 1571	White key set M210	M210610A-1	1	5	69	A	B
	5	6917 1580	Black key set M210	M210609-1	1	10	41	A	A
	6	6917 1591	Contact rubber M210	M210605A-1	1	5	80	B	B
	7	6917 1610	Slide knob 210	M310807-1	1	20	3	C	A
	8	6917 1630	Button 210A	M310824-1	1	20	29	B	A
	9	6917 1640	Button 210B	M310825-1	1	10	30	B	A
	10	6917 1730	Button 210B	M310825-2	1	5	30	B	B
	11		Top case 205B	M111690-2	1	1		C	
	12		Bottom case 205B	M111691-2	1	1		C	
	13		Screw	2.2 x 6	3	20		C	
	14		Screw	2.30 x 8 ZMC-3	6	20		C	

The parts having a blank in their code No. column should be ordered from C.M.F.G.

Notes: N – New parts
M – Minimum order/supply quantity
R – Rank

CASIO COMPUTER CO.,LTD.
Service Division

8-11-10, Nishi-Shinjuku
Shinjuku-ku, Tokyo 160, Japan
Telephone: 03-3347-4926

May, 1994