

SERVICE MANUAL & PARTS LIST

WK-240

JUN. 2014



CASIO®

Ver. 1 : Jul. 2014

CONTENTS

SPECIFICATIONS	1
BLOCK AND WIRING DIAGRAM	3
PCB INFORMATION	4
CIRCUIT DESCRIPTION	5
PRINTED CIRCUIT BOARDS	7
DISASSEMBLY	10
DIAGNOSTIC PROGRAM	21
EXPLODED VIEW	29
PARTS LIST	31
SCHEMATIC DIAGRAMS	36

SPECIFICATIONS

Keyboard	76 standard size keys
Touch Response	2 types, Off
Maximum Polyphony	48 notes (24 for certain tones)
Tones	
Built-in Tones	600
Sampling Tones	Up to 8 (Melody Sampling: 5, Drum Sampling: 3)* Up to 10 seconds
Functions	Layer, Split, Piano/Organ button
Virtual Hall	On, Off
Reverb	1 to 10, Off
Chorus	1 to 5, Off
Metronome	
Beats per Measure	0 to 9
Tempo Range	30 to 255
Song Bank	
Built-in Songs	152
User Songs	Up to 10*
Step Up Lesson	
Lessons	4 (Listen, Watch, Remember, Auto)
Lesson Part	L, R, LR
Functions	Repeat, Voice Fingering Guide, Note Guide, Performance Evaluation
Music Challenge	20 notes
Auto Accompaniment	
Built-in Rhythms	180
User Rhythms	Up to 10 (Accompaniment Edit)*
Chord Book Function	Chord guide
Registration	32 (4 setups × 8 banks)
Recorder	Real-time recording, playback
Keyboard Play	5 songs, 6 tracks
Playing Along with a Built-in Songs	1 song (L, R, LR)
Memory Capacity	Approximately 12,000 notes (total for 6 songs)
Other Functions	
Transpose	±1 octaves (–12 to +12 semitones)
Octave Shift	Upper/Lower ±2 octaves
Tuning	A4 = 415.5 to 465.9 Hz (Initial Default: 440.0 Hz)
Preset Scales	17
Music Preset	305
One Touch Preset	180
Auto Harmonize	12 types
Arpeggiator	90 types

MIDI	16 multi-timbre received, GM Level 1 standard
Musical Information Function	Tone, Rhythm, Song Bank numbers and names, staff notation, fingering, pedal operation, tempo, measure and beat number, chord name, etc.
Inputs/Outputs	
USB port	TYPE B
Sustain/Assignable jack	Standard jack (sustain, sostenuto, soft, rhythm)
Phones/Output jack	Stereo standard jack Output Impedance: 140 Ω, Output Voltage: 4.5 V (RMS) MAX
Audio In jack	Stereo mini jack Input Impedance: 9 kΩ, Input Sensitivity: 200 mV
Mic In/Sampling jack	Standard jack (connect a dynamic microphone only) Input Impedance: 3 kΩ, Input Sensitivity: 10 mV
Power Jack	DC 9.5 V
Power Supply	2-way
Batteries	6 D-size zinc-carbon batteries or alkaline batteries
Battery Life	Approximately 5 hours continuous operation on zinc-carbon batteries
AC Adaptor	AD-E95100L • The AC adaptor can be used safely in areas up to 4,000 meters above sea level.
Auto Power Off	Approximately 6 minutes (during battery operation) or 30 minutes (during AC adaptor operation) without any operation, Auto Power Off can be disabled.
Speakers	12 cm × 2 (Output: 2.5 W + 2.5 W)
Power Consumption	9.5 V --- 7.7 W
Dimensions	116.1 × 38.5 × 13.4 cm (45 ³ / ₄ × 15 ³ / ₁₆ × 5 ¹ / ₄ inch)
Weight	Approximately 6.9 kg (15.2 lbs) (without batteries)

* This data is stored in a shared memory area with a total capacity of approximately 320 Kbytes (1 Kbyte = 1,024 bytes).

BLOCK AND WIRING DIAGRAM

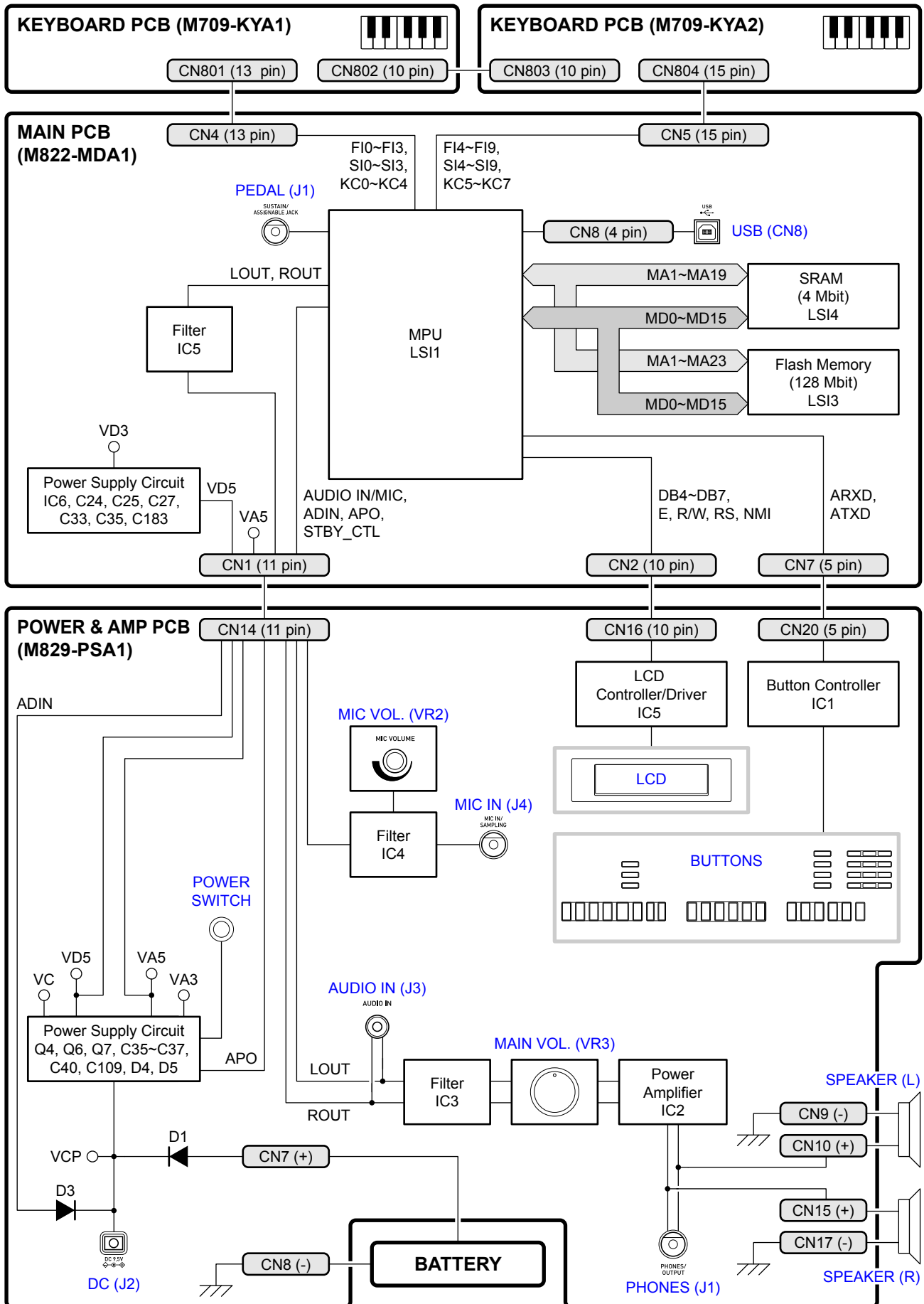

PCB INFORMATION

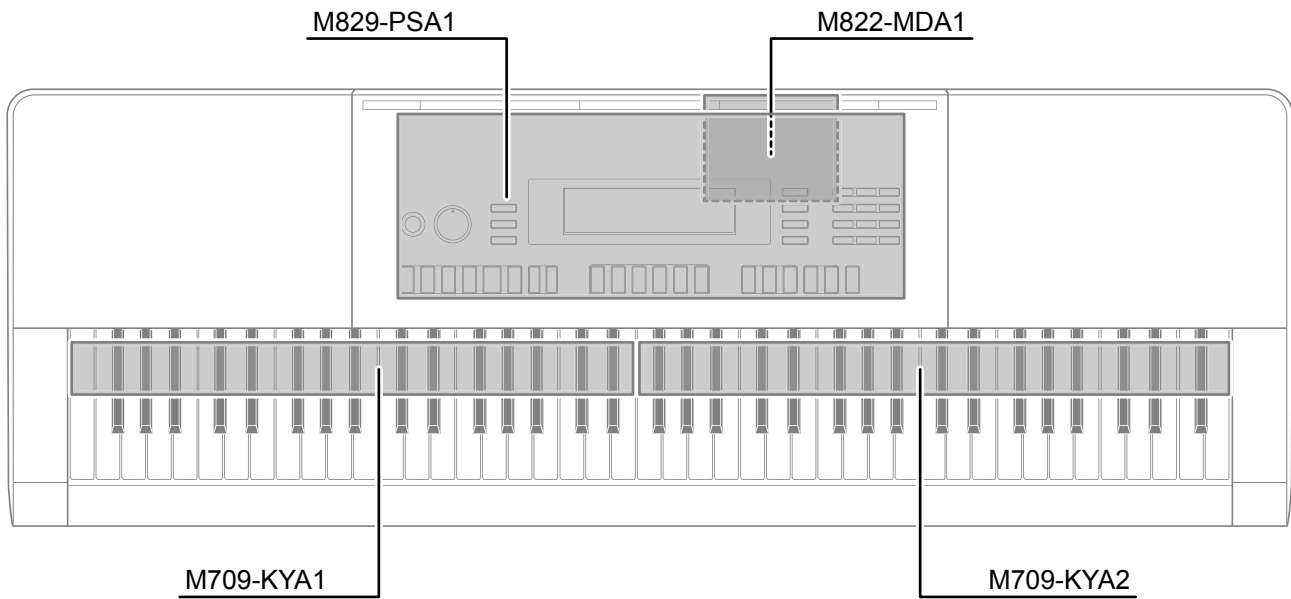

Parts Name	PCB Name	Functions
Main PCB		
PCB UNIT/MAIN	M822-MDA1	MPU, SRAM, Flash memory, Power supply circuit, Filter, SUSTAIN/ASSIGNABLE jack, USB port
Power & Amp PCB		
BACK LIGHT UNIT	M829-PSA1	Power supply circuit, Power amplifier, Filters, LCD controller/driver, Button controller, LCD, Buttons, Power switch, Main volume, Mic volume, DC terminal, AUDIO IN jack, PHONES/OUTPUT jack, MIC IN/SAMPLING jack, Speakers
Keyboard PCB		
PCB UNIT/KYA	M709-KYA1	Keyboard
	M709-KYA2	

CIRCUIT DESCRIPTION

■ Nomenclature of Keys

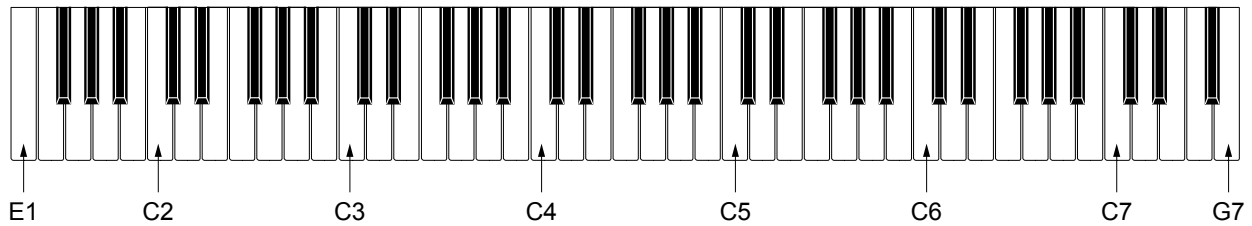

■ Key Matrix

Each key has two contacts, the first contact ① and second contact ②.

[NOTE] The diagram below illustrates how the contacts work.

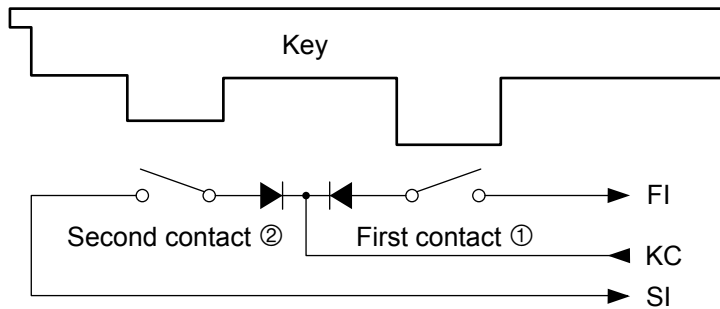

	KC0	KC1	KC2	KC3	KC4	KC5	KC6	KC7
FI0		E1①	F1①	F1#①	G1①	G1#①	A1①	A1#①
SI0		E1②	F1②	F1#②	G1②	G1#②	A1②	A1#②
FI1	B1①	C2①	C2#①	D2①	D2#①	E2①	F2①	F2#①
SI1	B1②	C2②	C2#②	D2②	D2#②	E2②	F2②	F2#②
FI2	G2①	G2#①	A2①	A2#①	B2①	C3①	C3#①	D3①
SI2	G2②	G2#②	A2②	A2#②	B2②	C3②	C3#②	D3②
FI3	D3#①	E3①	F3①	F3#①	G3①	G3#①	A3①	A3#①
SI3	D3#②	E3②	F3②	F3#②	G3②	G3#②	A3②	A3#②
FI4	B3①	C4①	C4#①	D4①	D4#①	E4①	F4①	F4#①
SI4	B3②	C4②	C4#②	D4②	D4#②	E4②	F4②	F4#②
FI5	G4①	G4#①	A4①	A4#①	B4①	C5①	C5#①	D5①
SI5	G4②	G4#②	A4②	A4#②	B4②	C5②	C5#②	D5②
FI6	D5#①	E5①	F5①	F5#①	G5①	G5#①	A5①	A5#①
SI6	D5#②	E5②	F5②	F5#②	G5②	G5#②	A5②	A5#②
FI7	B5①	C6①	C6#①	D6①	D6#①	E6①	F6①	F6#①
SI7	B5②	C6②	C6#②	D6②	D6#②	E6②	F6②	F6#②
FI8	G6①	G6#①	A6①	A6#①	B6①	C7①	C7#①	D7①
SI8	G6②	G6#②	A6②	A6#②	B6②	C7②	C7#②	D7②
FI9	D7#①	E7①	F7①	F7#①	G7①			
SI9	D7#②	E7②	F7②	F7#②	G7②			

■ Button Matrix

	SWO0	SWO1	SWO2	SWO3	SWO4	SWO5	SWO6
SWI0	BANK, LISTEN	Area1, WATCH	RHYTHM, ONE TOUCH PRESET	MUSIC PRESET	4	8	9
SWI1	Area2, REMEMBER	Area3, NEXT	SONG BANK	TONE	7	5	6
SWI2	Area4, AUTO	STORE, MUSIC CHALLENGE			1	2	+
SWI3	CHORDS, ACCOMP, PART SELECT	VAR./FILL-IN, FF	TEMPO ▼	VIRTUAL HALL, DEMO	0	-	3
SWI4	NORMAL/FILL-IN, REW	START/STOP, PLAY/STOP		TEMPO ▲	SPLIT	RECORDER, SAMPLING	AUTO HARMONIZE/ ARPEGGIATOR, TYPE
SWI5	INTRO, REPEAT	SYNCHRO/ ENDING, PAUSE	METRONOME, BEAT	RHYTHM EDITOR	LAYER	PIANO/ORGAN, CHORD BOOK	FUNCTION

PRINTED CIRCUIT BOARDS

Main PCB: M822-MDA1

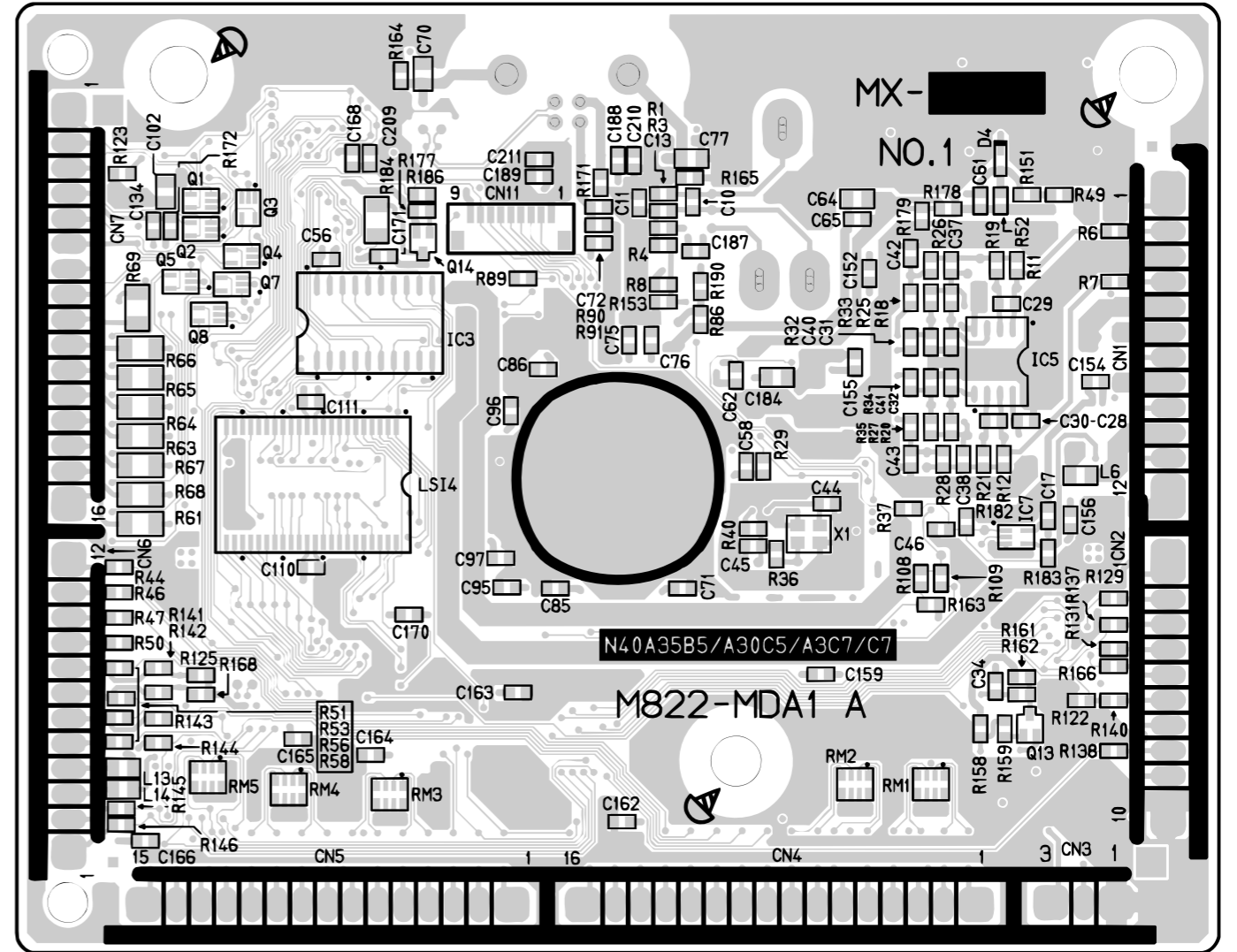
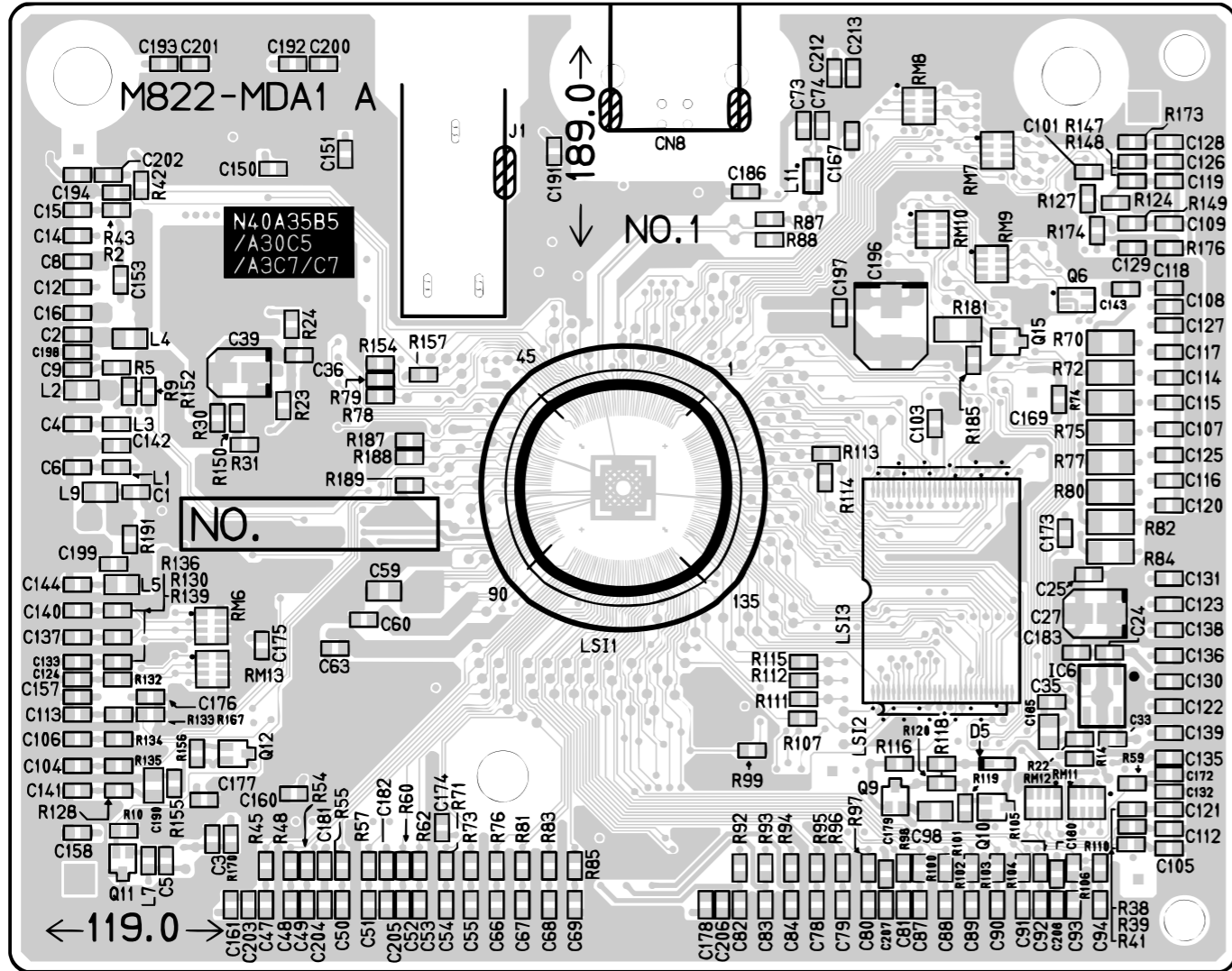

Power & Amp PCB: M829-PSA1

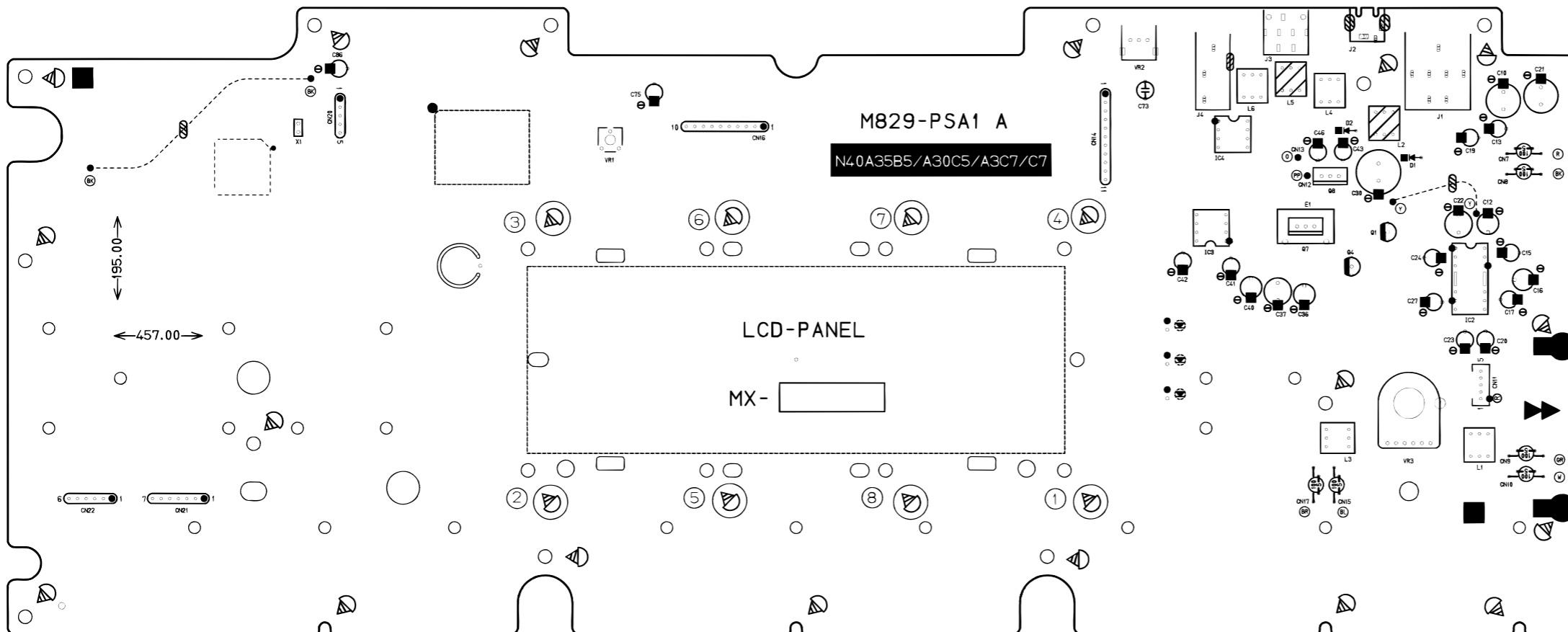
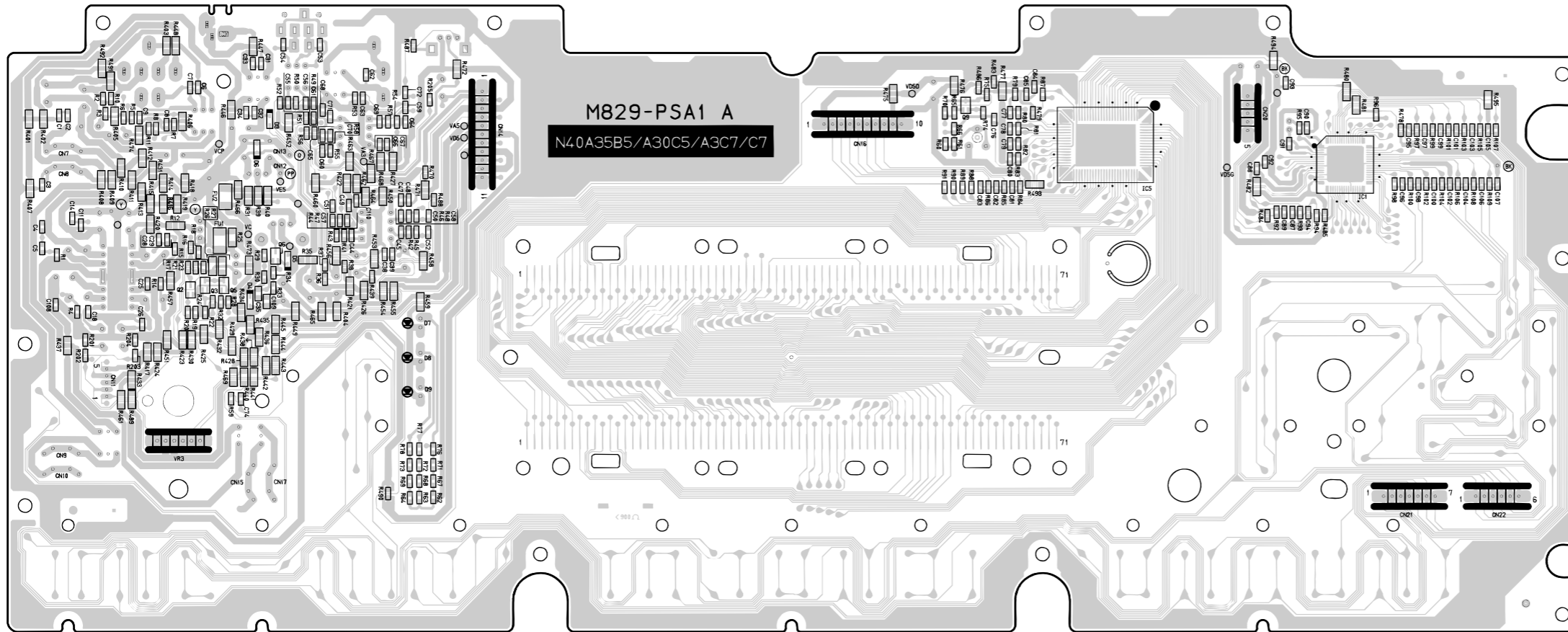

Keyboard PCB: M709-KYA1

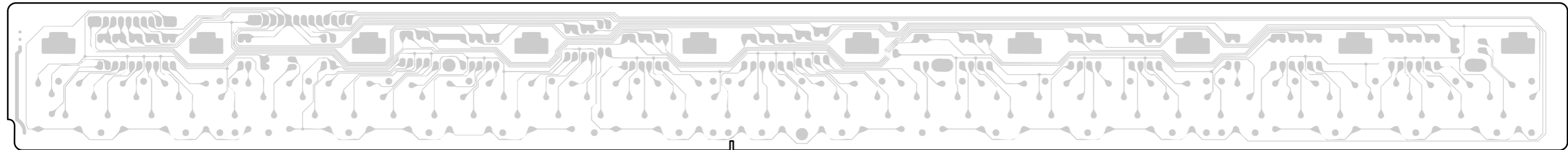
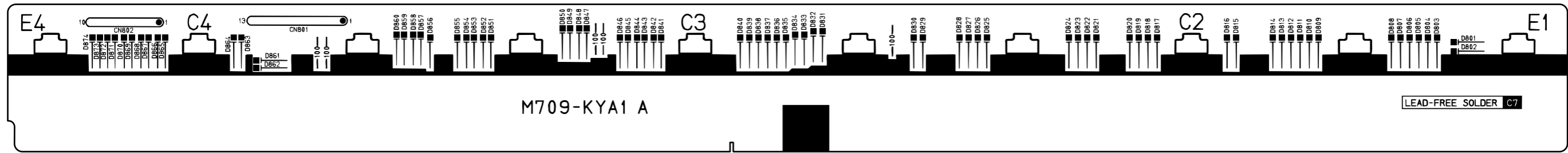

Keyboard PCB: M709-KYA2

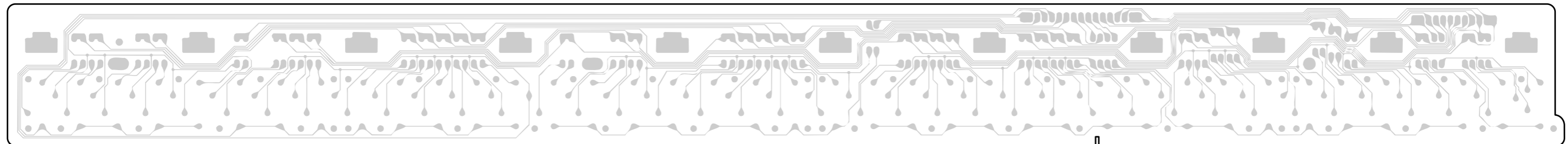
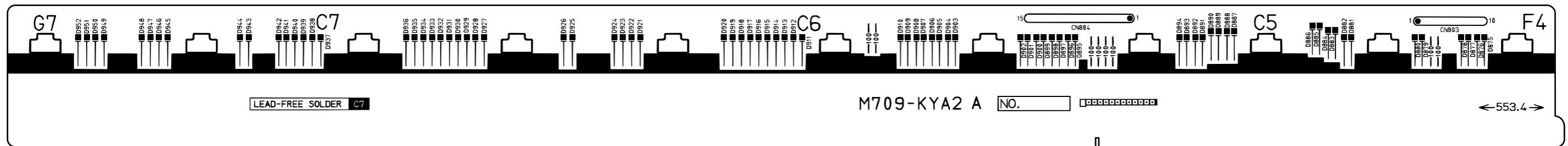

DISASSEMBLY

■ About Repair

- The figures in this chapter show a prototype, so the appearance of parts may slightly differ from the actual parts.
- To avoid damages to the instrument and floor, lay the instrument on a mattress or blanket before starting disassembling.
- There are several kinds of screws. Be sure to use the correct type of screws when assembling. It is advisable to sort the screws as shown below after removing them.

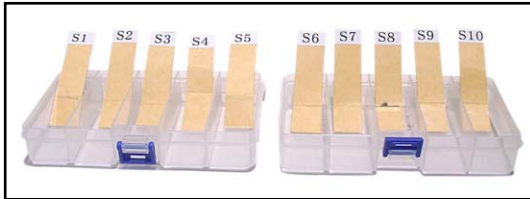

- If a screw cap is attached to the screw, remove it. When assembling, reattach the screw cap.
- Check how cables are wired before removing cables. When assembling, wire the cables in the same manner as they were before disassembly.
- If a cable is bound by cable tie, tape or similar item, remove it as necessary. When assembling, bind the cable as it was before disassembly.

■ Before Starting Repair or Servicing

- Remove the AC adaptor, AC cord or batteries.
- Remove accessories such as the music stand.

■ Disassembly Procedures

Flowchart

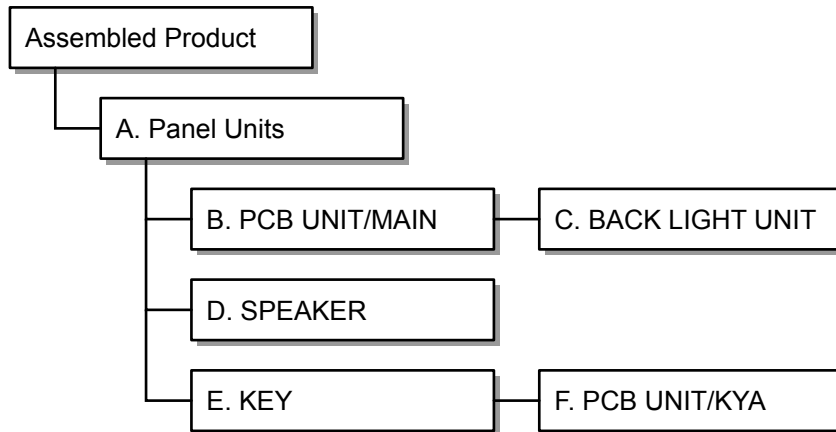

A. Remove the Panel Units

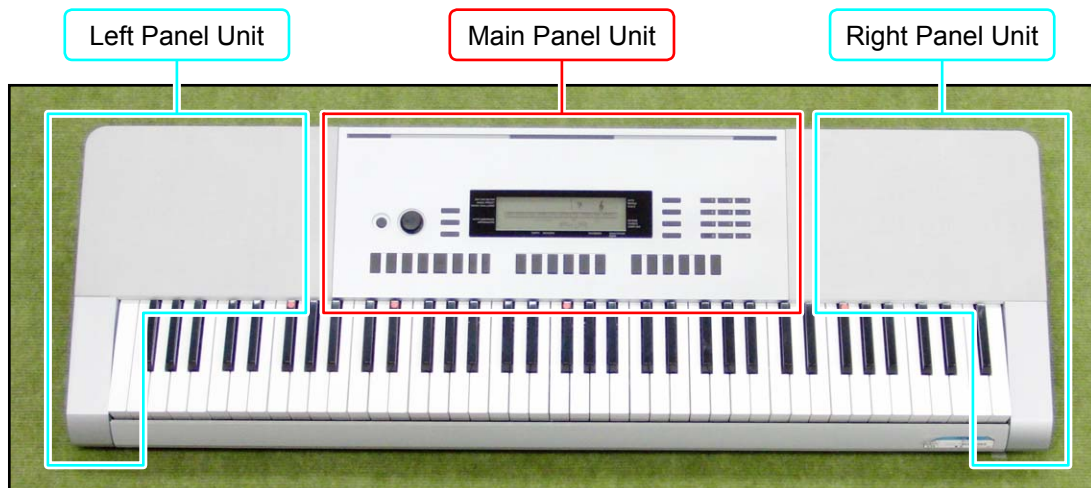

A-1. Undo 21 or seven screws on the bottom surface.

[NOTE] To remove only the Main Panel Unit, undo seven screws indicated with red circles in the figure below.

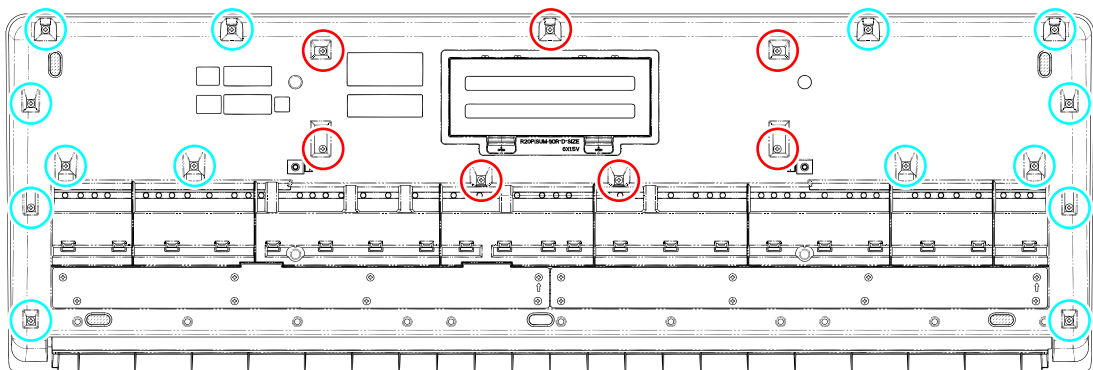

A-2. Place the digital keyboard with keyboard facing up.

A-3. Lift the Main Panel Unit and turn it over.

[NOTE] The Main Panel Unit is connected to the lower case with the cables. Use caution when turning over the panel unit.

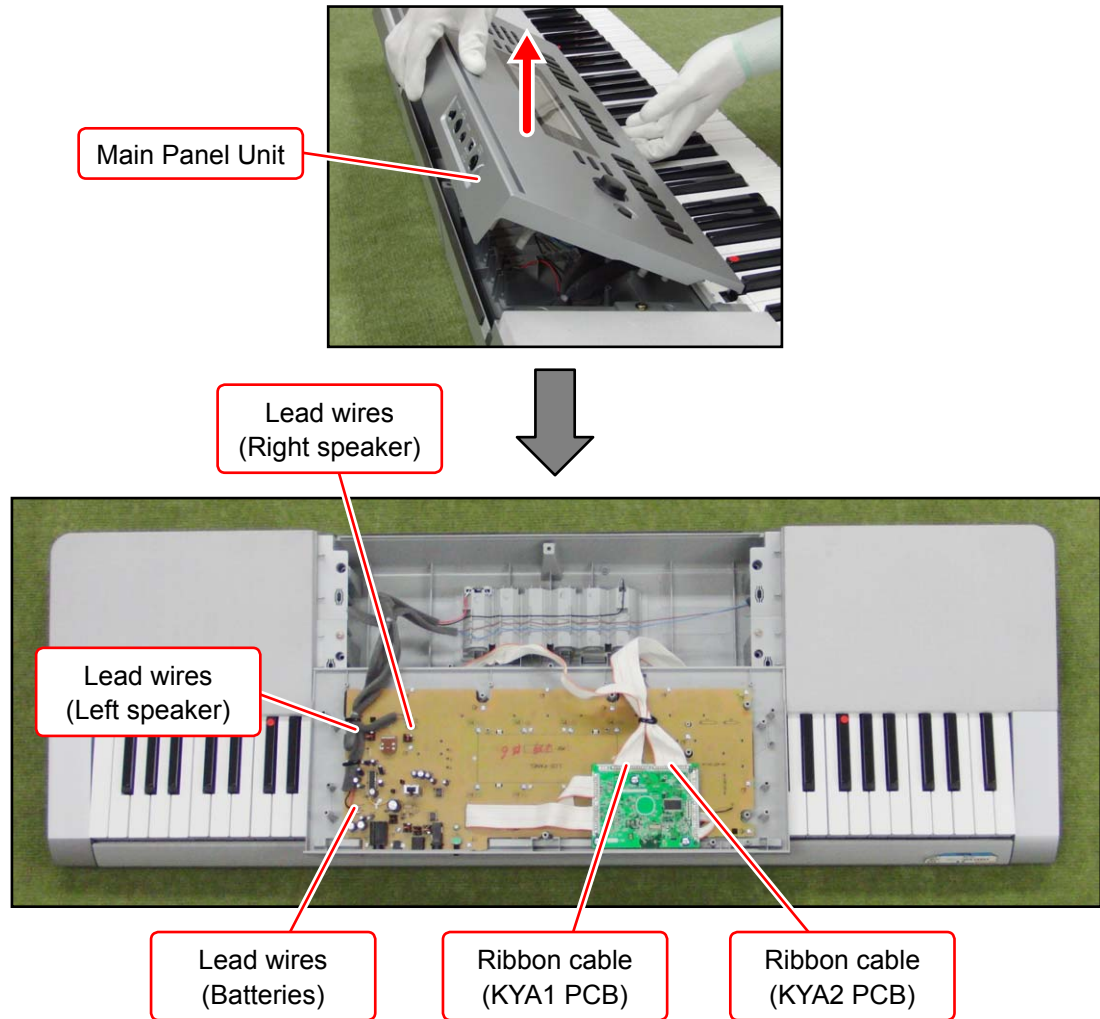

A-4. Unsolder six lead wires and two ribbon cables to remove the Main Panel Unit.

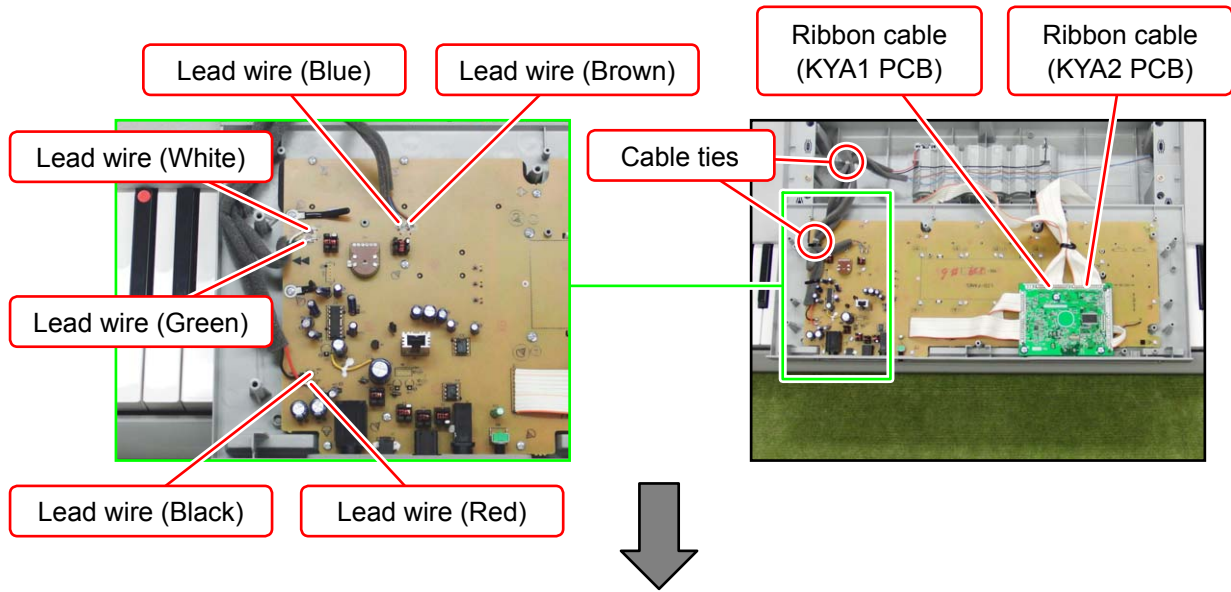

Notes on Assembly

- The number of pins on the PCB pad differs from that on the cable. Solder in the way that No.1 pin on the cable (orange) is connected to No.1 pad on the PCB.

Ribbon cable (KYA1 PCB)
PCB: 16 pads
Cable: 13 pins

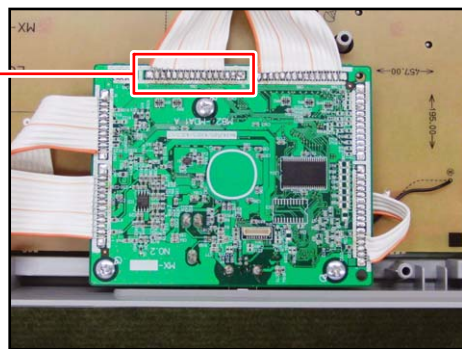

A-5. Undo one screw and remove the Right Panel Unit.

A-6. Undo one screw and remove the Left Panel Unit.

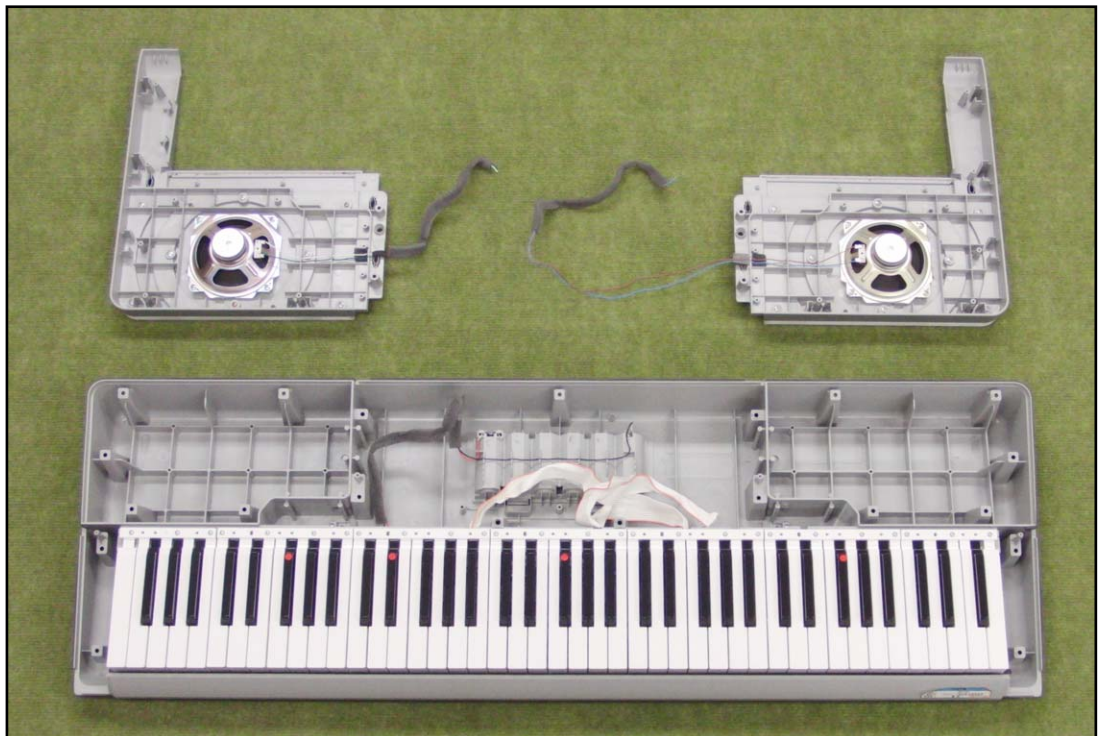
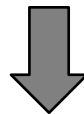
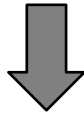
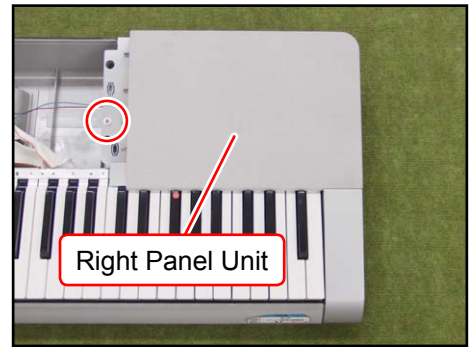
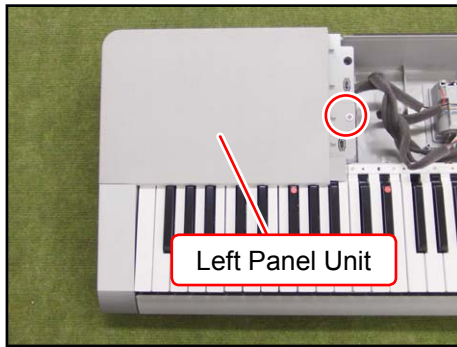

B. Remove the PCB UNIT/MAIN

B-1. Unsolder three ribbon cables.

B-2. Undo three screws to remove the PCB UNIT/MAIN.

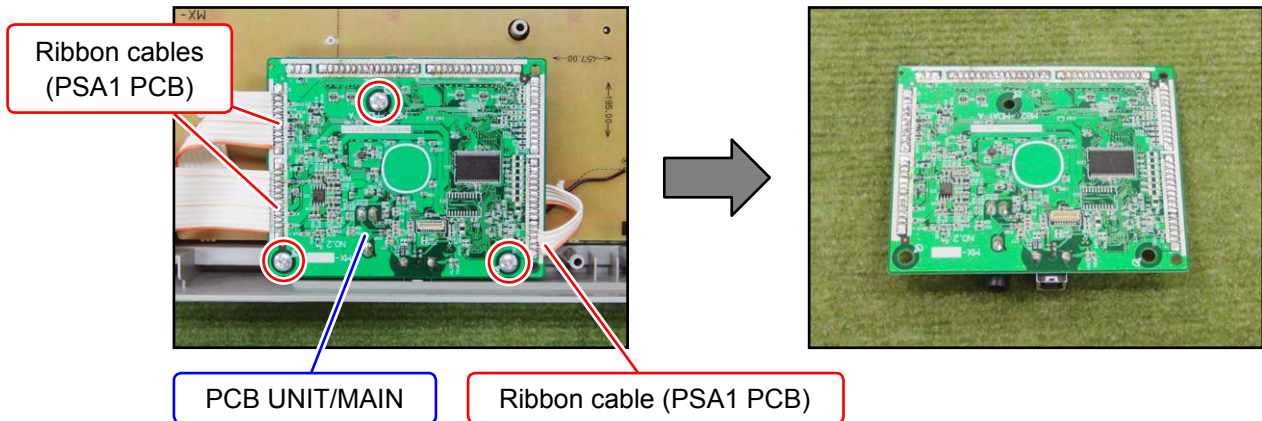

Notes on Assembly

- The number of pins on the PCB pad differs from that on the cable.
Solder in the way that No.1 pin on the cable (orange) is connected to No.1 pad on the PCB.

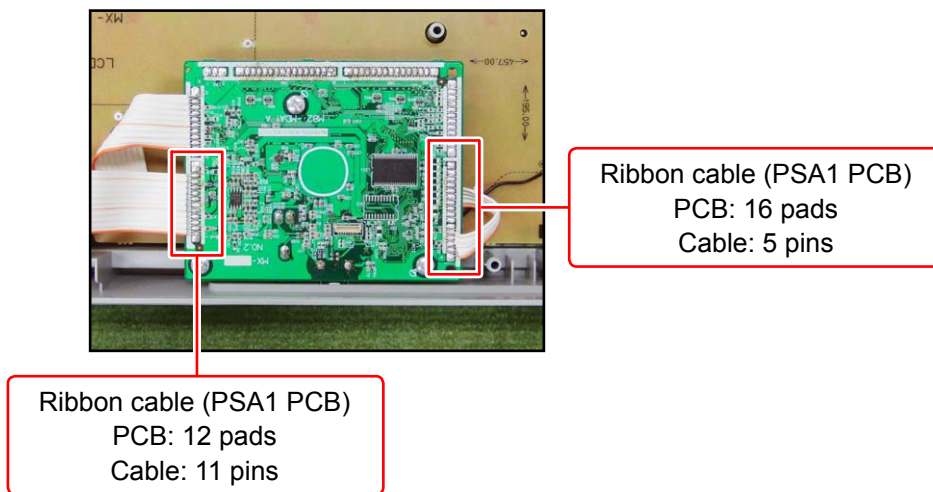

C. Remove the BACK LIGHT UNIT

C-1. Remove the KNOB/ROTARY.

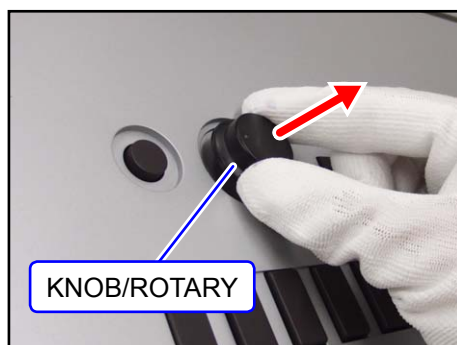

C-2. Undo 27 screws and remove the BACK LIGHT UNIT, seven RUBBER BUTTON, and LCD components.

[NOTE] There are three types of screws. Be sure to use the correct screw when assembling.

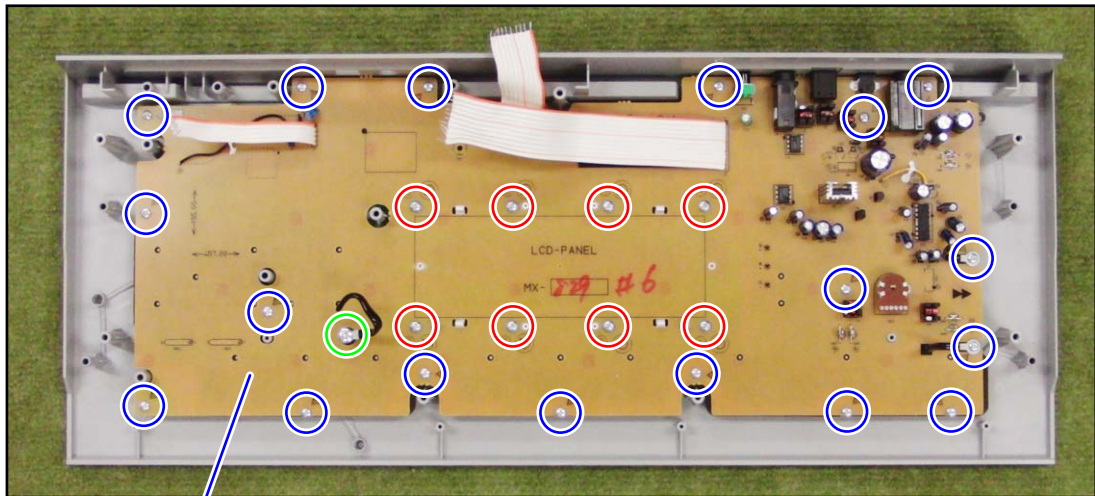

BACK LIGHT UNIT

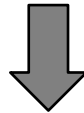

BACK LIGHT UNIT

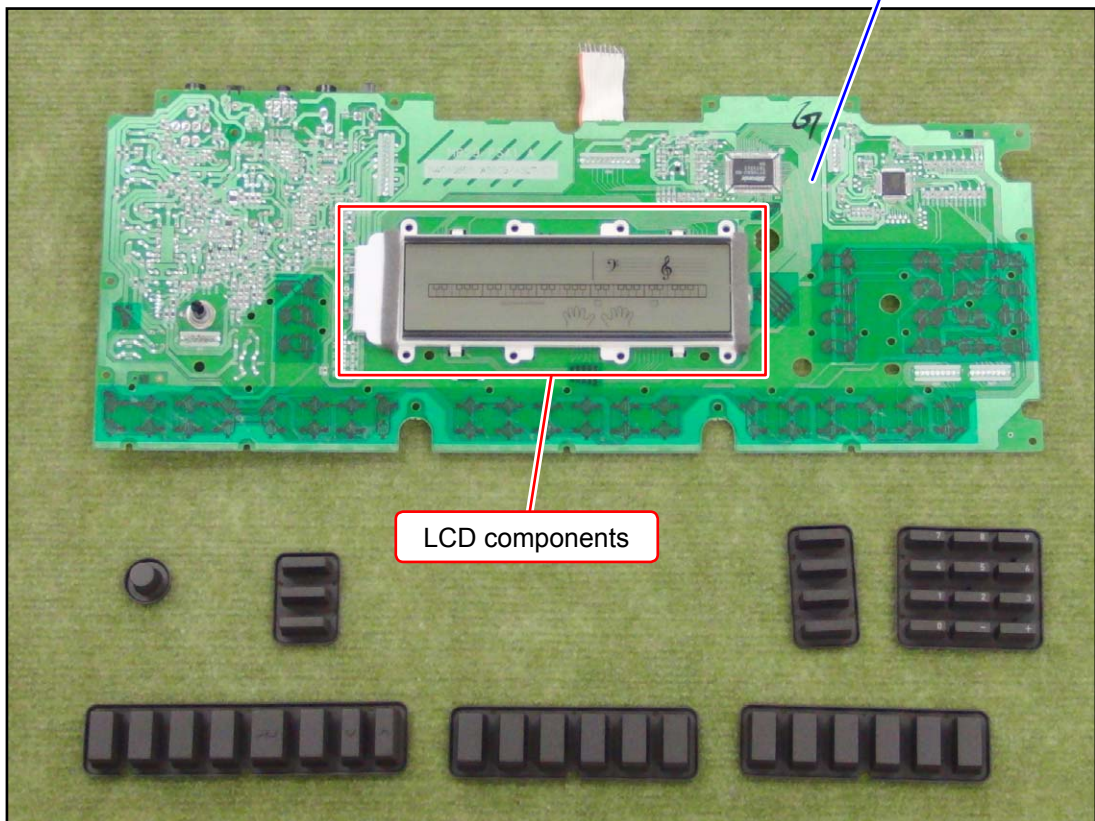

LCD components

Notes on Assembly

- To install the BACK LIGHT UNIT, tighten the screws for the LCD part in the order indicated by the numbers shown on the right. If not tightened correctly, it may cause LCD display errors.

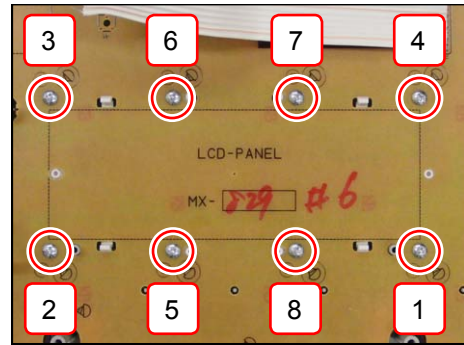

D. Remove the SPEAKER

- D-1. Unsolder two lead wires.
- D-2. Undo four screws and remove the SPEAKER.

<Left speaker>

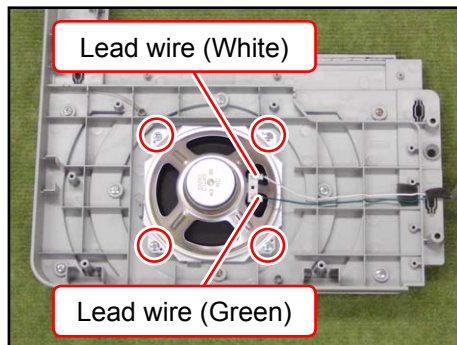

<Right speaker>

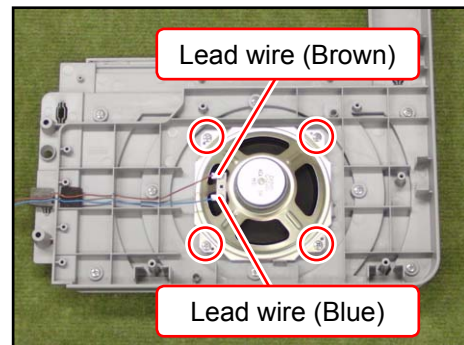

E. Remove the KEY

E-1. Undo 26 screws and then remove the WHITE KEY and BLACK KEY.

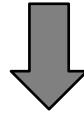
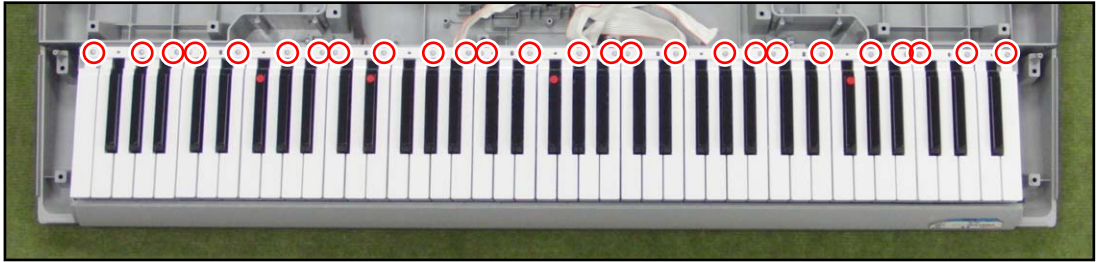

F. Remove the PCB UNIT/KYA

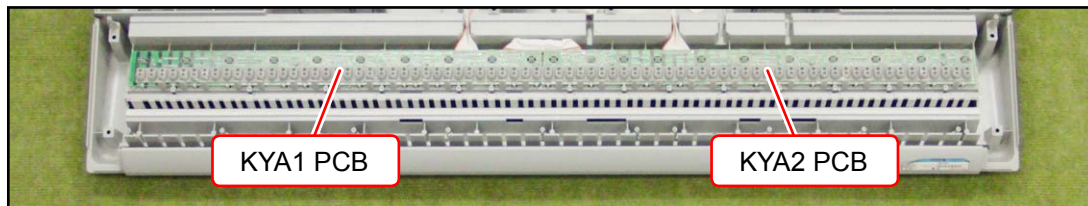

F-1. Unhook and remove the PCB UNIT/KYA.

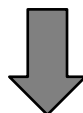
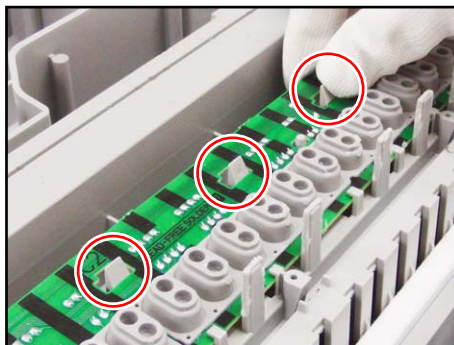

F-2. Remove seven RUBBER CONTACT.

[NOTE] There are three types of RUBBER CONTACT with differing lengths.

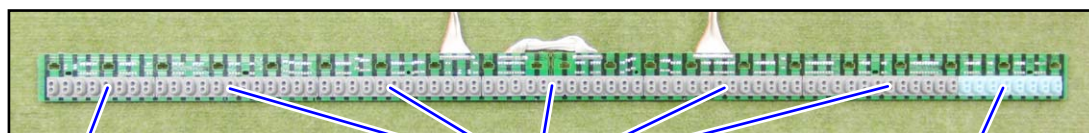



RUBBER CONTACT/SEB

RUBBER CONTACT/CB

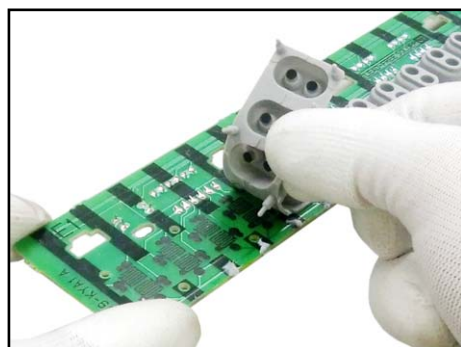
RUBBER CONTACT/CSG



Color	Length	Image
RUBBER CONTACT/SEB		
Grey	106.15 mm	
RUBBER CONTACT/CB		
Grey	162.10 mm	
RUBBER CONTACT/CSG		
Blue	109.10 mm	

How to Install the RUBBER CONTACT

- Lightly insert the tip of a RUBBER CONTACT into the PCB. Pull the tip from the back of the PCB and install it using a tool such as tweezers. Do not forcibly pull it.

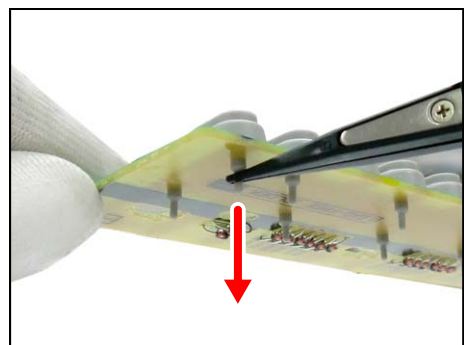

DIAGNOSTIC PROGRAM

■ Preparation

- (1) Connect the AC adaptor.

[NOTE] The AC adaptor for the WK-240_DI and WK-240_UK is sold separately.

[NOTE] If you do not have the AC adaptor, use six D-size dry batteries with enough capacity. If you use the batteries, do not perform the “AC Adaptor Check”.
- (2) Adjust the main volume so that it is at about 1/3 of the full volume.
- (3) Have a pedal (SP-3 or SP-20) ready.

[NOTE] SP-3 and SP-20 are sold separately.

The “Pedal Check” cannot be performed without a pedal.
- (4) Have a PC and USB cable ready.

[NOTE] Please refer to the User’s Guide for PC system requirements.

[NOTE] The “USB Check” cannot be performed without a PC and a USB cable.

■ How to Start the Diagnostic Program

- (1) Turn on the power while holding down the [0], [1] and [2] buttons.

[NOTE] When the test is finished, be sure to press the power button to turn off the power.

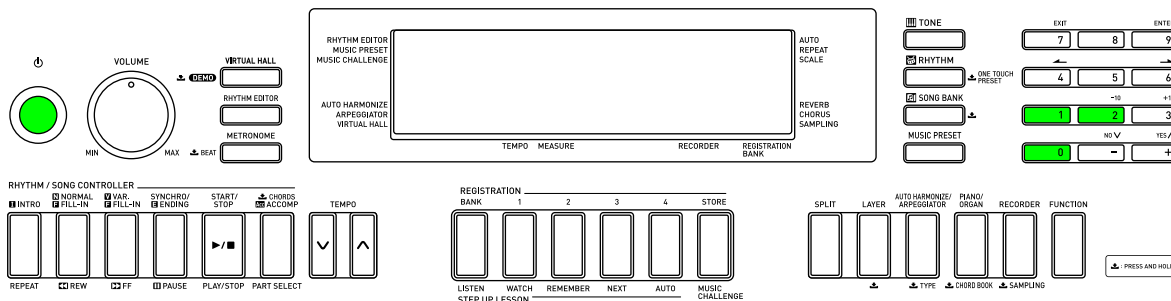

- (2) Release the [0], [1] and [2] buttons.

When the diagnostic program is launched, the Test Mode screen appears.

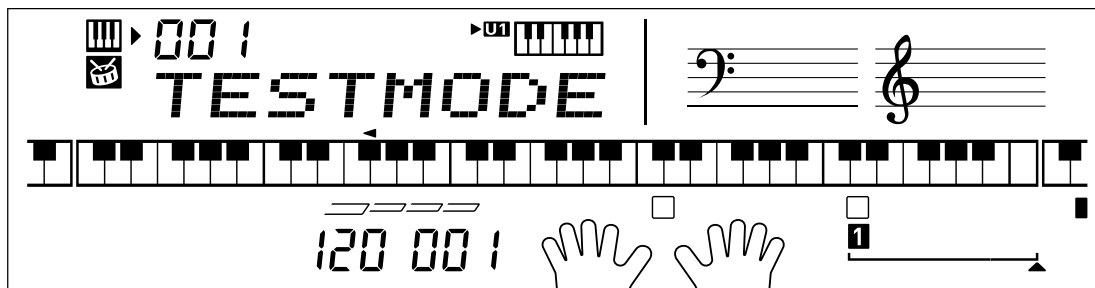

■ Test Items

Pressing a test button after the diagnostic program was launched or while on the main screen enables the corresponding test item to be tested.

Test Item	Button	Remarks
A. Button Check	1	
B. AC Adaptor Check	3	AC adaptor
C. ROM Check	5	
D. RAM Check	6	
E. ROM Version Check	9	
F. Model Check	9	
G. LCD Check	2	
H. Pedal Check	RHYTHM	Pedal (SP-3 or SP-20)
I. USB Check		PC, USB cable

<Test Mode Main Screen>

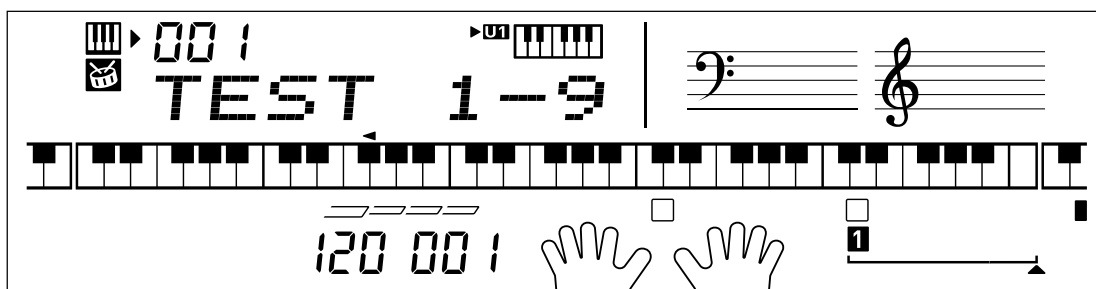

■ Test Procedures

A. Button Check

A-1. Press the [1] button to select the "Button Check".

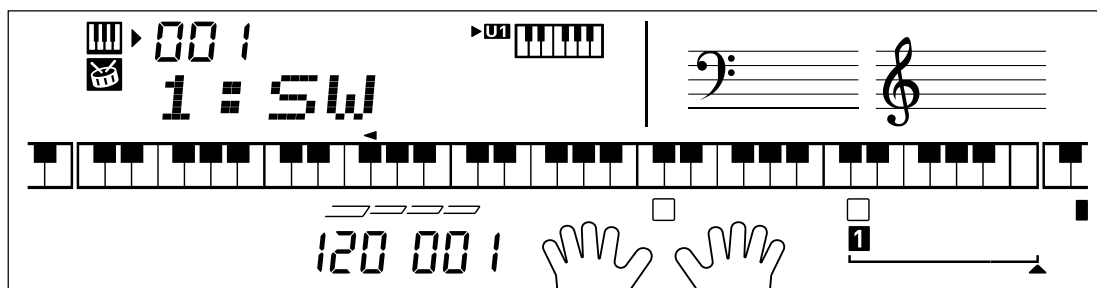

A-2. Press the buttons in the order indicated in the figure below.

If the result passes (OK):

- The confirmation tone sounds and “1:SW00” and button number shown below “XX” appears.

If the result fails (NG):

- If there is a button failure or the buttons are pressed in a wrong sequence, the error tone sounds and the button number which you pressed will be appears.

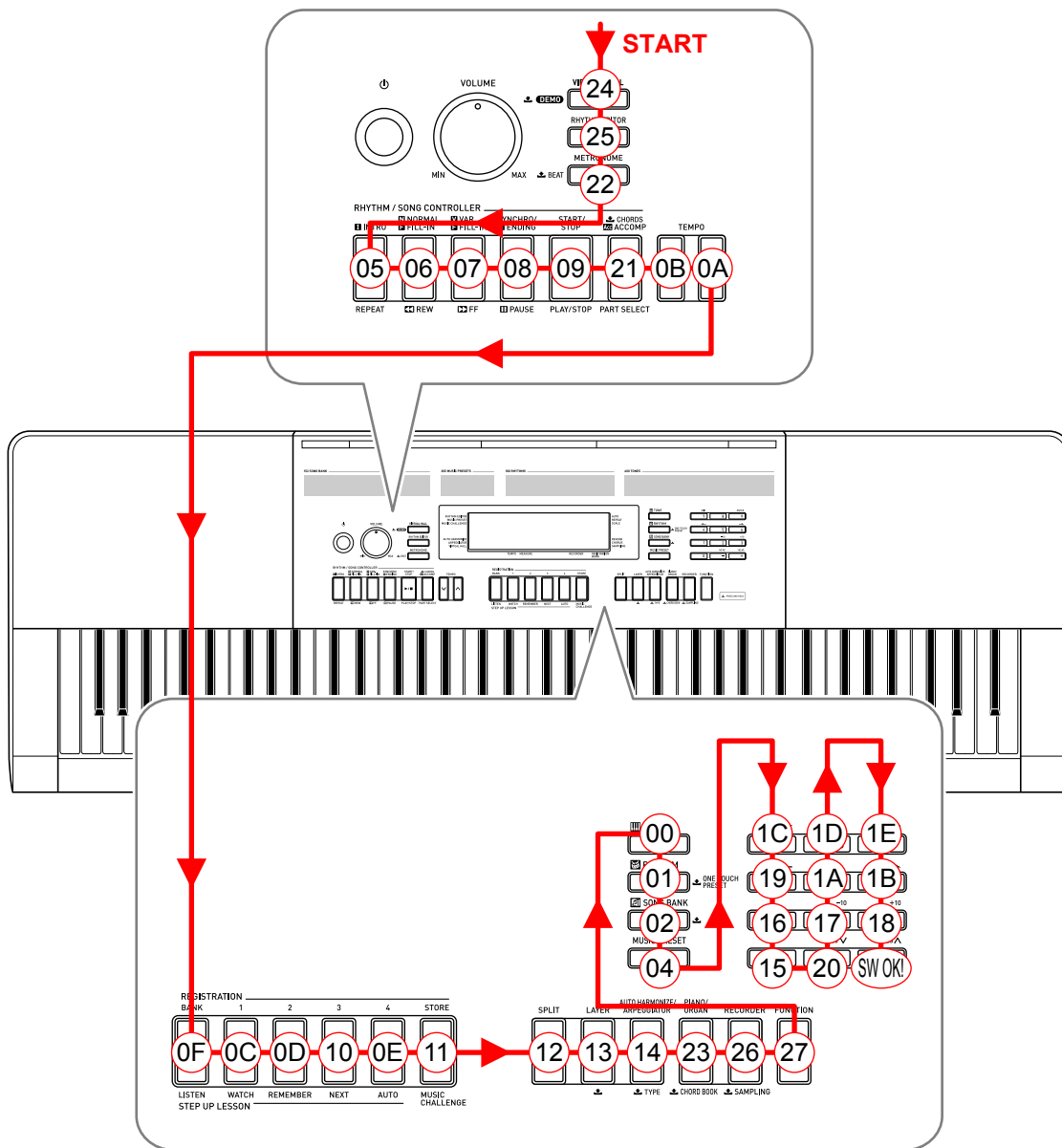
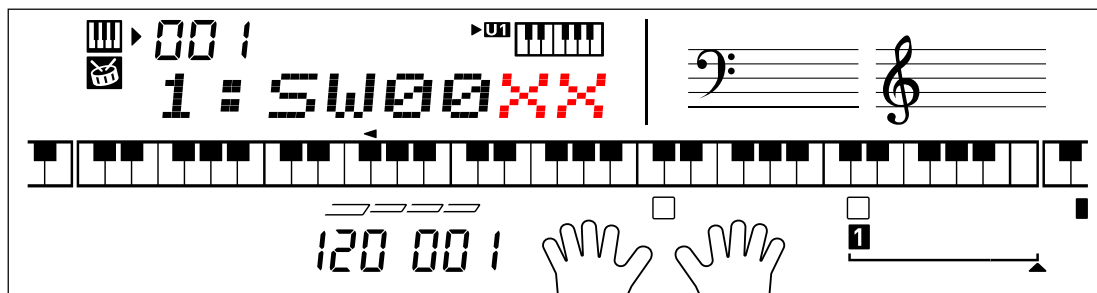

A-3. Check that the following screen appears.

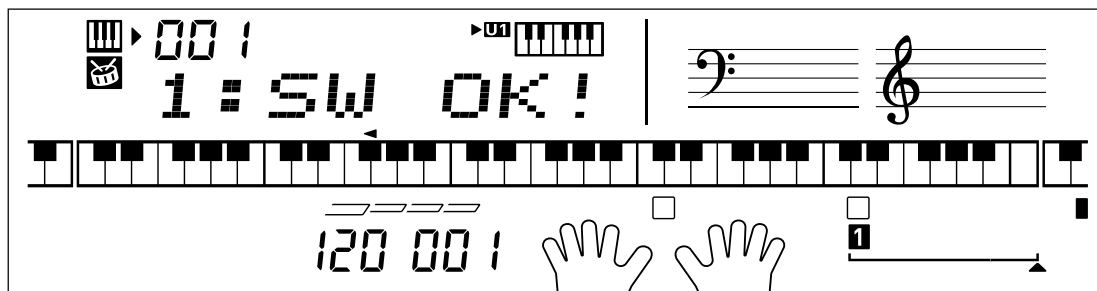

A-4. Press the [0] button to return to the main screen.

B. AC Adaptor Check

[NOTE] If you use the batteries, do not perform this check.

B-1. Press the “3” button to select the “AC Adaptor Check”.

B-2. Press the “3” button again.

B-3. Check that “AD3xxx” is displayed.

[NOTE] “xxx” is in the range of “000” to “1FF”.

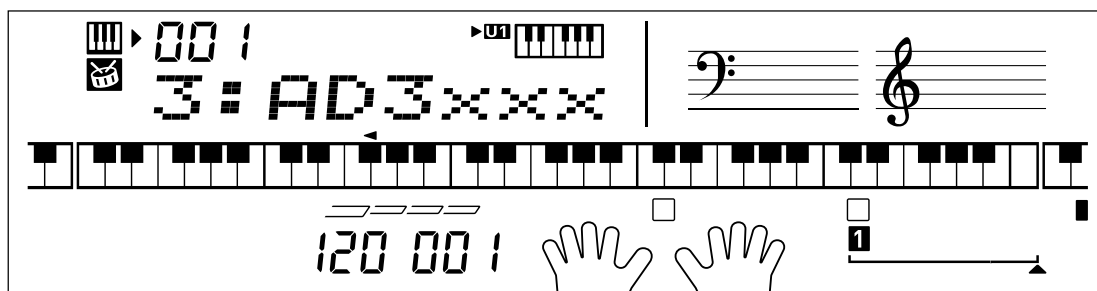

B-4. Press the [0] button to return to the main screen.

C. ROM Check

C-1. Press the [5] button to select the “ROM Check”.

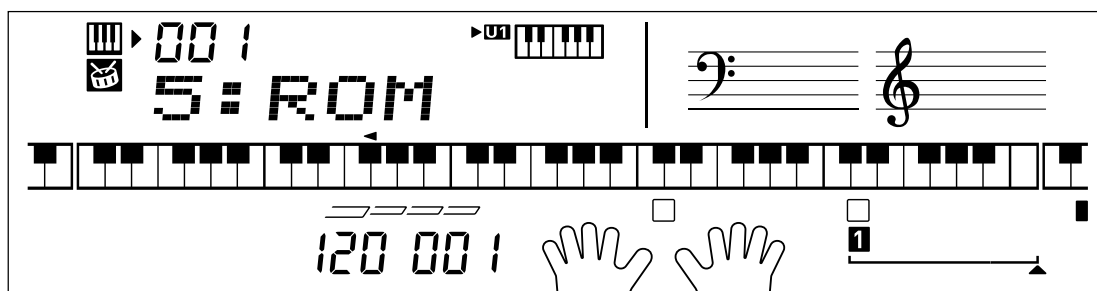

C-2. Press the [1] button to start the check.

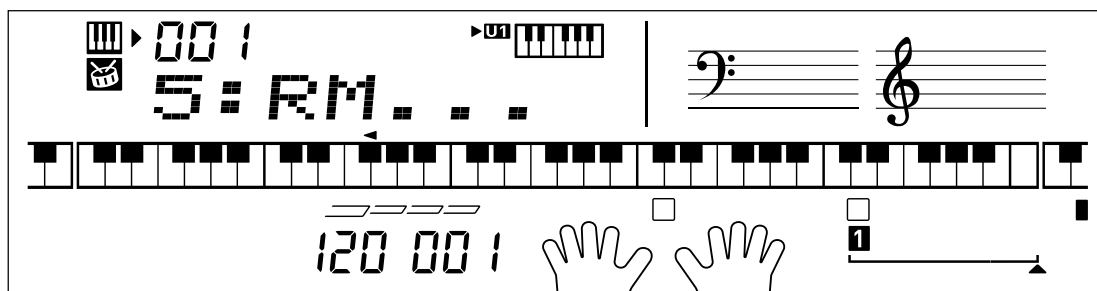

C-3. Check that the following screen appears.

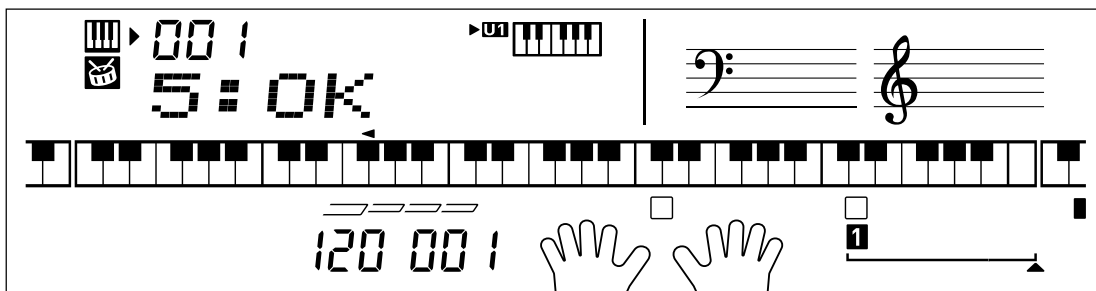

C-4. Press the [0] button to return to the main screen.

D. RAM Check

D-1. Press the [6] button to select the "RAM Check".

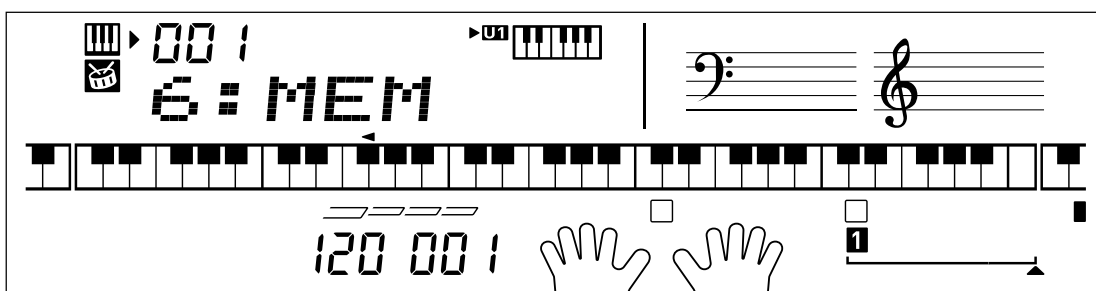

D-2. Press the [1] button to start the check.

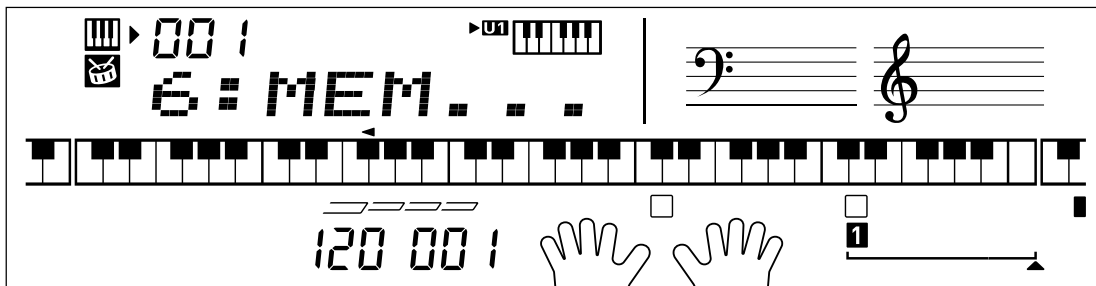

D-3. Check that the following screen appears.

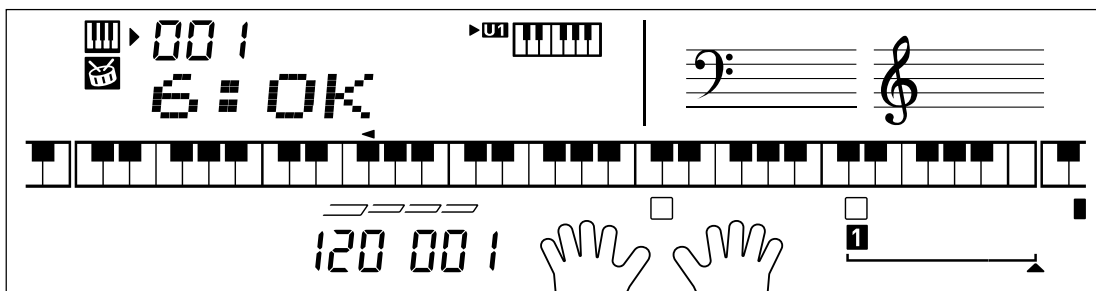

D-4. Press the [0] button to return to the main screen.

E. ROM Version Check

(This section describes how to identify the ROM version, not to test it.)

E-1. When you press the [9] button, the ROM version appears as shown below.

* The displayed ROM version may differ depending on the individual products.

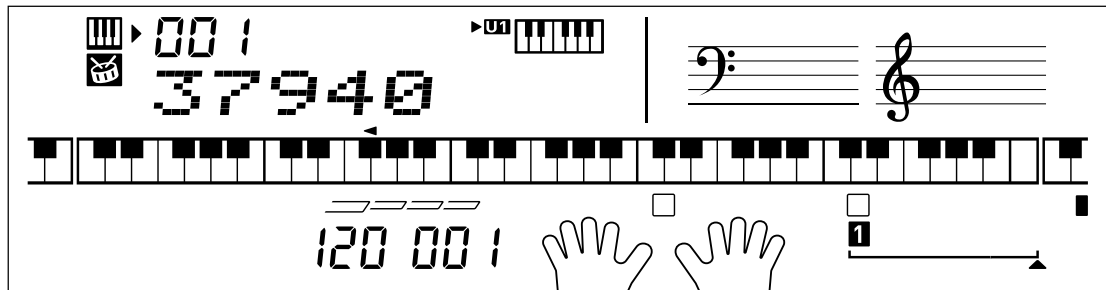

E-2. Press the [0] button to return to the main screen.

F. Model Check

F-1. Press the [9] button.

The ROM version appears.

F-2. Press the [9] button again to perform the "Model Check".

F-3. Check that the model name is "MX829CD".

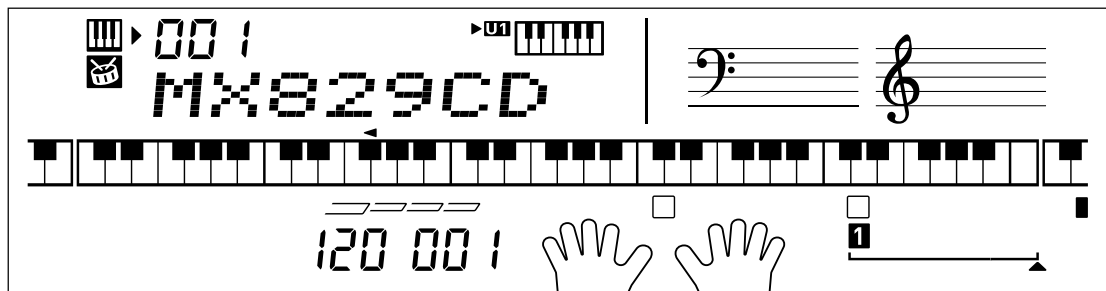

F-4. Press the [0] button to return to the main screen.

G. LCD CHECK

G-1. Press the [2] button to select the "LCD Check".

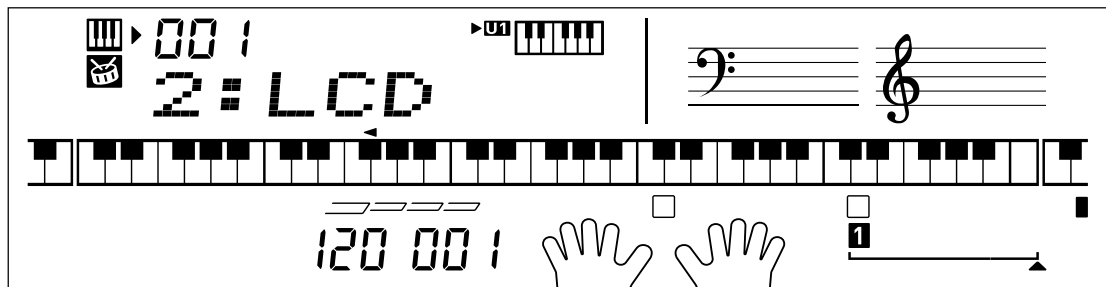

G-2. Press the [2] button and check that all segments are lit.

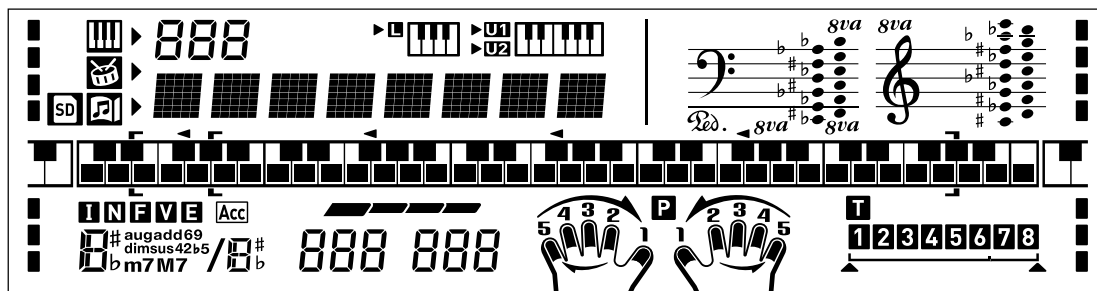

G-3. Press the [2] button and check that all segments are turned off.

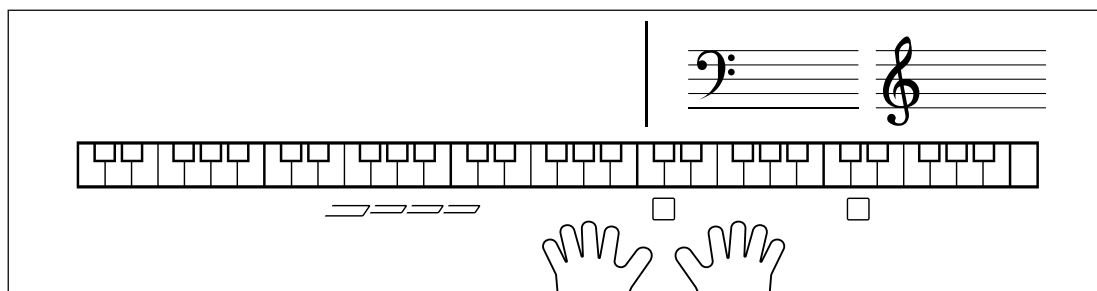

G-4. Press the [0] button to return to the main screen.

H. Pedal Check

[NOTE] This check cannot be performed without a pedal.

H-1. Connect the pedal to the SUSTAIN/ASSIGNABLE jack.

H-2. Press the [RHYTHM] button to select the "Pedal Check".

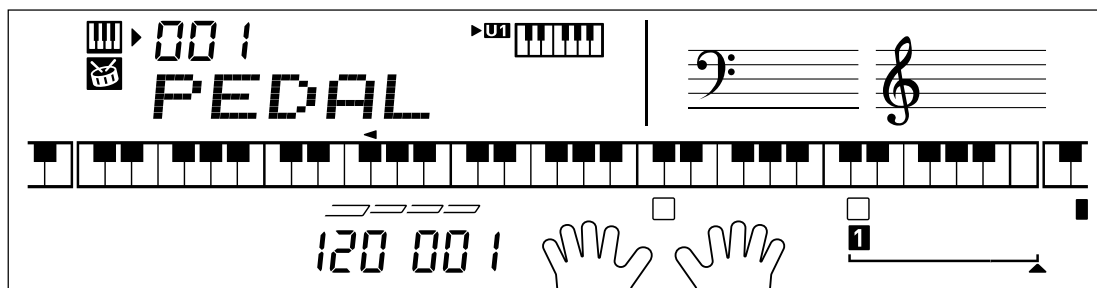

H-3. Press the pedal and check that the following screen appears.

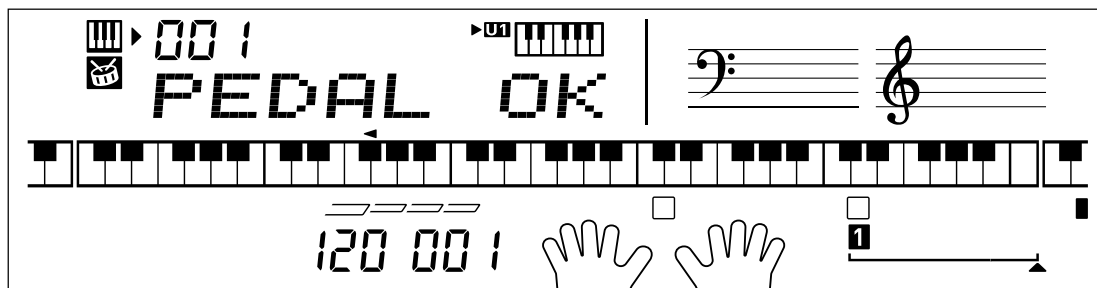

H-4. Press the [0] button to return to the main screen.

I. USB Check

[NOTE] This check cannot be performed without a PC and a USB cable.

[NOTE] The following procedure is for Windows.

- I-1. Connect the digital keyboard to the PC with a USB cable.
- I-2. Open the Windows “Device Manager” and check that “USB Audio Devices” or “CASIO USB-MIDI” is listed under the “Sound, video and game controllers”.
 - **Windows XP:** USB Audio Devices
 - **Windows Vista / 7 / 8:** CASIO USB-MIDI
- I-3. Disconnect the USB cable and check that the “USB Audio Devices” or “CASIO USB-MIDI” is not listed under the “Sound, video and game controllers”.

EXPLODED VIEW

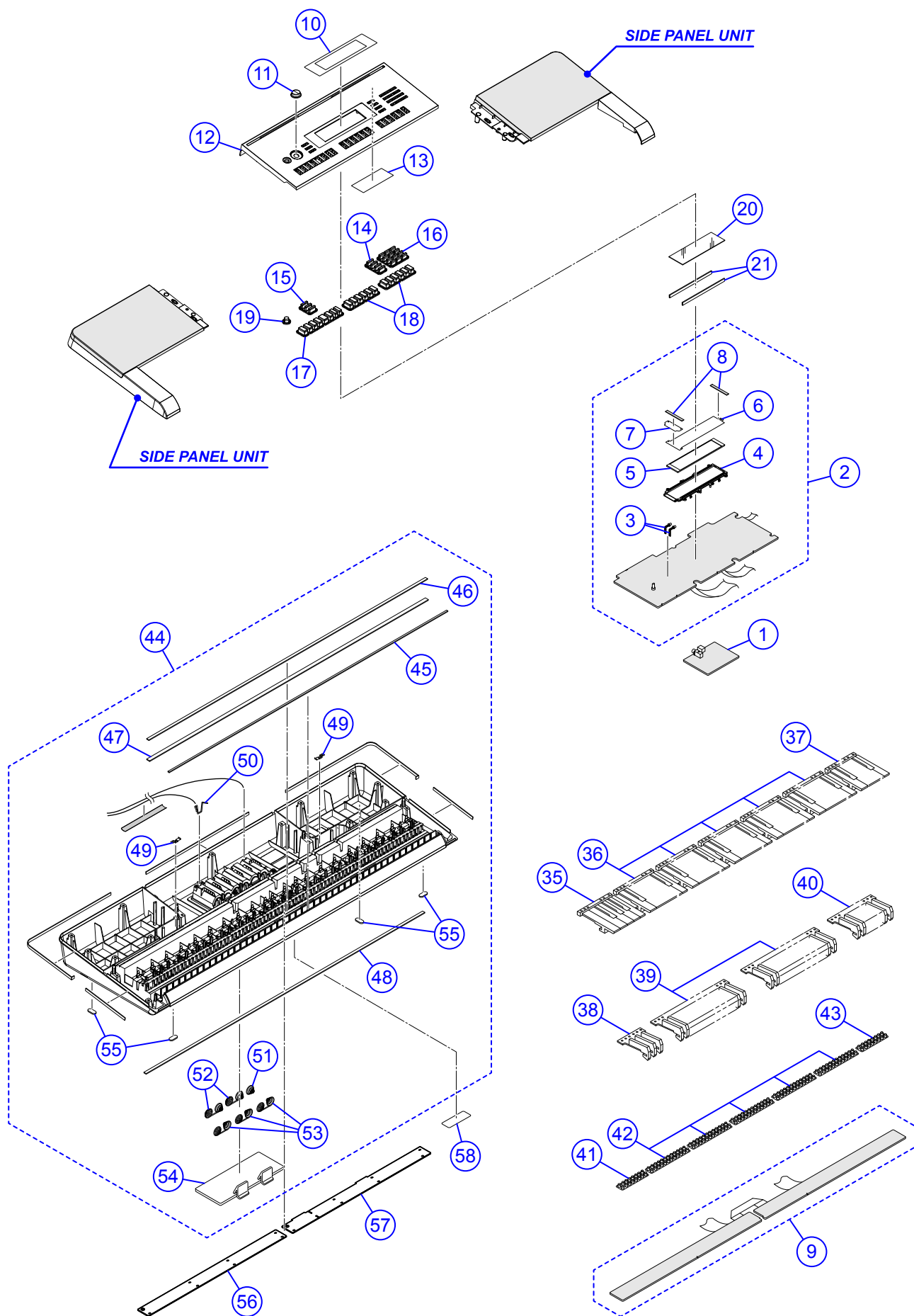

LEFT SIDE PANEL UNIT

RIGHT SIDE PANEL UNIT

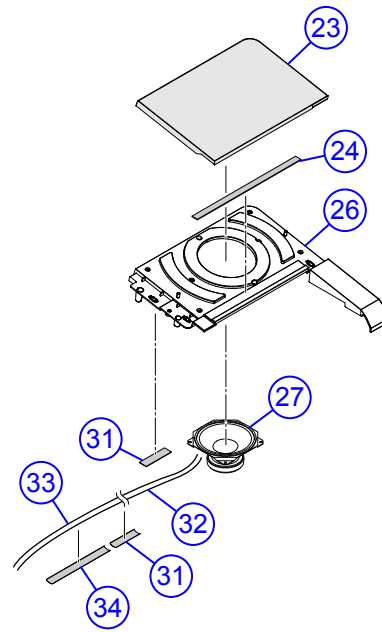
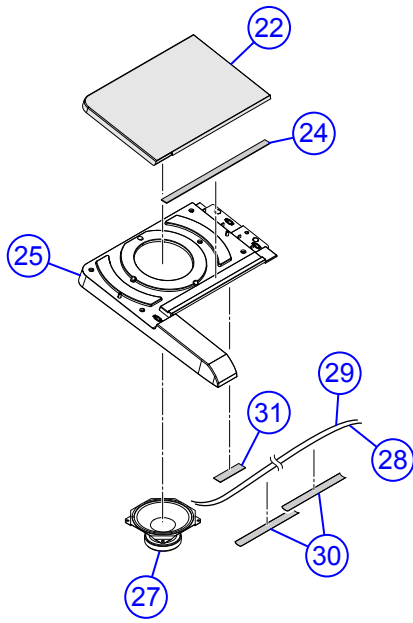

Detail: Left

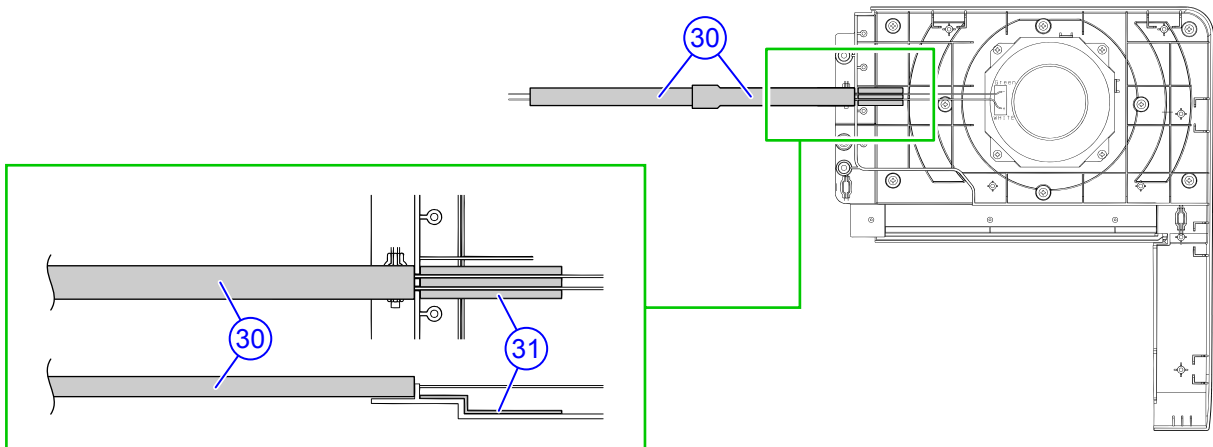

Detail: Right

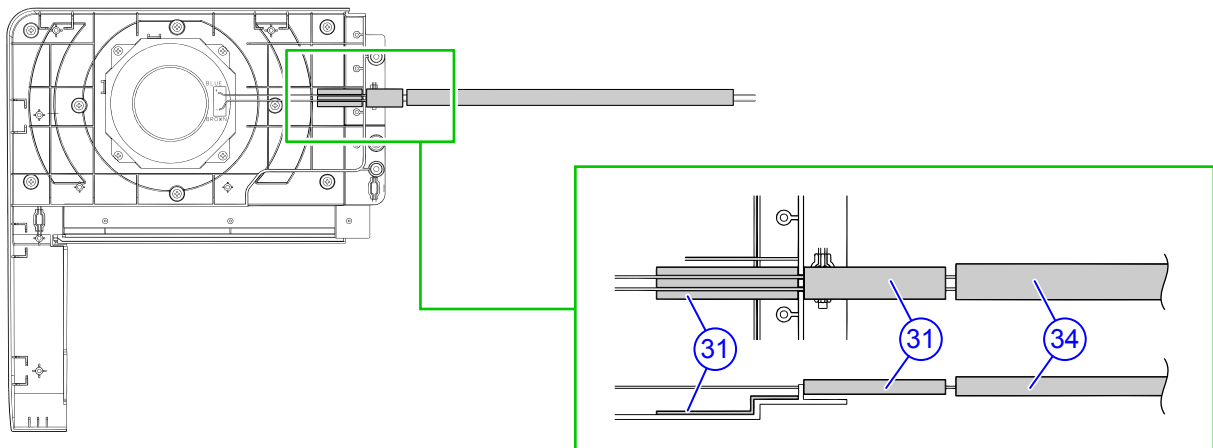

PARTS LIST

[Notes]

1. Prices and specifications are subject to change without prior notice.
2. Refer to the latest “Parts Price Code” at “PARTS FINDER” on the Casio Service Website (<https://www.servicecasio.com>).
3. As for spare parts order and supply, refer to the “GUIDEBOOK for Spare Parts Supply”, published separately.
4. The numbers in item column correspond to the same numbers in drawing.

- 1: WK-240_DI
- 2: WK-240_EU
- 3: WK-240_UK
- 4: WK-240_US

N	Item	Code No.	Parts Name	Specification	Q'ty				R	Remarks	
					1	2	3	4			
Main PCB											
N	1	10480919	PCB UNIT/MAIN	TK-RJM513625*001	1	1	1	1	A	MDA1	
	CN8	10236624	CONNECTOR/USB	UBR24-4K5G00	1	1	1	1	B		
	J1	10206815	JACK/SUSTAIN	JY-6314*01-030	1	1	1	1	B		
	D4	10009218	DIODE	1SS400TE61	1	1	1	1	X		
	IC5	10211950	IC	NJM2068M-D(TE1)	1	1	1	1	X		
	IC6	10398240	IC	XC6402FV36PR-G	1	1	1	1	X		
	L11	10193074	COIL	DLW21HN181SQ2L	1	1	1	1	X		
	LSI4	10256784	LSI/MEMORY	CY62146EV30LL45ZST	1	1	1	1	C		
	Q12,Q13	10399706	TRANSISTOR	DSC500100L	2	2	2	2	X		
	X1	10375016	RESONATOR	7V48080006	1	1	1	1	X		
Back Light Unit (including Power & Amp PCB and Console)											
	2	10399936	BACK LIGHT UNIT	TK-RJM511233*001	1	1	1	1	B	PSA1	
	J2	35015103	JACK/DC	HEC3110-01-010	1	1	1	1	C		
	J4	10206816	JACK/MIC IN	JY-6314*01-130	1	1	1	1	C		
	J1	10305218	JACK/PHONES	JY-6316B*01-070	1	1	1	1	C		
	J3	10305131	JACK/AUDIO IN	ST-3529B	1	1	1	1	C		
	VR2	10398245	VARIABLE RESISTOR	F-09KV-CASIO-2	1	1	1	1	B		Mic volume
	VR3	10407265	VARIABLE RESISTOR	F164KPD-1N-CASIO-4	1	1	1	1	B		Main volume
	IC3,IC4	10206677	IC	NJM2068D-D	2	2	2	2	X		
	IC2	10300598	IC	TA8227APL-D12-H-T	1	1	1	1	X		
	IC5	10222381	LSI	ST7066U-0A-QG	1	1	1	1	X		
	IC1	10159709	LSI	UPD65881GK-1019ETA	1	1	1	1	X		
	L2,L5	10231919	COIL	RB53-856396NP	2	2	2	2	X		
	L1,L3,L4,L6	10231920	COIL	RB53-856397NP	4	4	4	4	X		
	Q7	10206835	TRANSISTOR	KTA1046-Y-U/P	1	1	1	1	X		
	X1	10093909	RESONATOR	CSBLA1M00J58-B0	1	1	1	1	X		
	D3,D5	23901820	DIODE	1SS355TE-17	2	2	2	2	X		
	D1,D2	10261170	DIODE	SRT14-A2	2	2	2	2	X		
	D4	23603102	DIODE	UDZSTE-175.1B	1	1	1	1	X		

- 1: WK-240_DI
- 2: WK-240_EU
- 3: WK-240_UK
- 4: WK-240_US

N	Item	Code No.	Parts Name	Specification	Q'ty				R	Remarks
					1	2	3	4		
	Q2,Q3,Q5,Q6,Q9	10399706	TRANSISTOR	DSC500100L	5	5	5	5	X	
	Q1	10217742	TRANSISTOR	KTA1270-Y-AT/P	1	1	1	1	X	
	Q4	10206675	TRANSISTOR	KTA1273-Y-AT/P	1	1	1	1	X	
	3	10308432	LED	SLR343BD2T3F	2	2	2	2	X	
	4	10123033	REFLECTOR	RJM502534-001V01	1	1	1	1	X	
	5	10122917	BACK LIGHT PLATE	RJM502475-001V01	1	1	1	1	X	
	6	10122970	FILM	RJM502473-001V01	1	1	1	1	X	
	7	10081190	TOP PIECE	RJM501982-001V01	1	1	1	1	X	
	8	10270485	SPONGE/8X75	M441167-001	2	2	2	2	X	
Keyboard PCB										
	9	10399944	PCB UNIT/KYA	TK-RJM508870*003	1	1	1	1	C	KYA1/KYA2
	D801-D952	23153132	DIODE	1SS133T-77	152	152	152	152	X	
Panel Unit										
N	10	10480920	DISPLAY PLATE	RJM511158-004V01	1	1	1	1	X	
	11	10399707	KNOB/ROTARY	M341109-012V01	1	1	1	1	C	
N	12	10480924	CASE/PANEL	RJM511092-004V03	1	1	1	1	X	
	13	10401543	SHEET/V-ZERO	RJM511424-001V01	1	1	1	1	X	
	14	10399732	RUBBER BUTTON/A	RJM511119-001V01	1	1	1	1	X	
N	15	10480921	RUBBER BUTTON/B	RJM511120-003V01	1	1	1	1	X	
	16	10399743	RUBBER BUTTON/C	RJM511133-001V01	1	1	1	1	X	
	17	10399736	RUBBER BUTTON/D	RJM511122-001V01	1	1	1	1	X	
	18	10399738	RUBBER BUTTON/E	RJM511123-001V01	2	2	2	2	X	
	19	10399741	RUBBER BUTTON/P	RJM511125-001V01	1	1	1	1	X	
	20	10402782	LCD	ZAS-TY012724DN00	1	1	1	1	X	
	21	10310620	RUBBER CONNECTOR/for LCD	RJM505823-002V01	2	2	2	2	X	

- 1: WK-240_DI
- 2: WK-240_EU
- 3: WK-240_UK
- 4: WK-240_US

N	Item	Code No.	Parts Name	Specification	Q'ty				R	Remarks
					1	2	3	4		
Side Panel Unit										
N	22	10480922	SPEAKER NET/LEFT	RJM511336*002V01	1	1	1	1	X	
N	23	10480923	SPEAKER NET/RIGHT	RJM511337*002V01	1	1	1	1	X	
	24	69251950	FABRIC TAPE/13X280	M440368-1	2	2	2	2	X	
	25	10399730	CASE/SIDE PANEL/LEFT	RJM511093-001V01	1	1	1	1	X	
	26	10399731	CASE/SIDE PANEL/RIGHT	RJM511094-001V01	1	1	1	1	X	
N	27	10472328	SPEAKER	CJ12FD02	2	2	2	2	X	
	28	10401520	WIRE/WHITE	1007TASC24450W3030	1	1	1	1	X	for Left speaker +
	29	10401519	WIRE/GREEN	1007TASC24450G3030	1	1	1	1	X	for Left speaker -
N	30	69261580	SPONGE/35X150	M440499-1	2	2	2	2	X	for Left speaker
	31	10127790	SPONGE/20X40	RJM503059-001V02	3	3	3	3	X	
	32	10377008	WIRE/BROWN	1007TASC24850T3030	1	1	1	1	X	for Right speaker -
	33	10377007	WIRE/BLUE	1007TASC24850B3030	1	1	1	1	X	for Right speaker +
	34	10135484	SPONGE/30X300	RJM503496-001V01	1	1	1	1	X	for Right speaker
Keyboard Unit										
	35	10399719	WHITE KEY/SEB	RJM507652*002V01	1	1	1	1	B	
	36	10304687	WHITE KEY/CB	TK-RJM507243*002	5	5	5	5	A	
	37	10399720	WHITE KEY/CSG	RJM507653*002V01	1	1	1	1	B	
	38	10289648	BLACK KEY/3p	RJM506595-007V02	1	1	1	1	B	
	39	10289646	BLACK KEY/10p	RJM506595-005V02	2	2	2	2	A	
	40	10289649	BLACK KEY/8p	RJM506595-008V02	1	1	1	1	B	
	41	10269450	RUBBER CONTACT/SEB	RJM507649-001V01	1	1	1	1	B	
	42	10269451	RUBBER CONTACT/CB	RJM507656-001V01	5	5	5	5	A	
	43	10269449	RUBBER CONTACT/CSG	RJM507650-001V01	1	1	1	1	B	
Main Case Unit										
	44	10399939	CASE UNIT/MAIN	TK-RJM511164*001	1	1	1	1	X	
	45	10399750	FELT/DAMPER/KEYBOARD	RJM511238-001V01	1	1	1	1	X	
	46	10406872	FELT/LOWER LIMIT/KEYBOARD	RJM511237-002V01	1	1	1	1	X	
	47	10406873	FABRIC TAPE	RJM511554-001V01	1	1	1	1	X	

- 1: WK-240_DI
- 2: WK-240_EU
- 3: WK-240_UK
- 4: WK-240_US

N	Item	Code No.	Parts Name	Specification	Q'ty				R	Remarks
					1	2	3	4		
	48	10399748	FELT/UPPER LIMIT/KEYBOARD	RJM511236-001V01	1	1	1	1	X	
	49	10284332	BRACKET/for Stand	M440866-001V02	2	2	2	2	X	
	50	10263726	BATTERY TERMINAL/+	M441101-001V02	1	1	1	1	X	
	51	10263727	BATTERY TERMINAL/-	M441102-001V02	1	1	1	1	X	
	52	10263724	BATTERY TERMINAL/A	M441099-001V02	2	2	2	2	X	
	53	10263725	BATTERY TERMINAL/B	M441100-001V02	3	3	3	3	X	
	54	10399937	BATTERY COVER	TK-M341288*012	1	1	1	1	X	
	55	10263730	RUBBER FOOT	M441160-001V01	4	4	4	4	X	
	56	10403459	LOWER COVER	RJM507741-002V02	1	1	1	1	X	
	57	10399747	LOWER COVER	RJM511159-001V01	1	1	1	1	X	
N	58	10480925	LABEL/RATING	RJM513003-023V01	1	1	1	1	X	
Accessories										
N	-	10408260	AC ADAPTOR	AD-E95100LU-P2				1	B	for US
	-	10411436	AC ADAPTOR	AD-E95100LG-P3		1			B	for EU
	-	10025472	MUSIC STAND	M141071-1	1	1	1	1	C	

SCHEMATIC DIAGRAMS

Main PCB: M822-MDA1

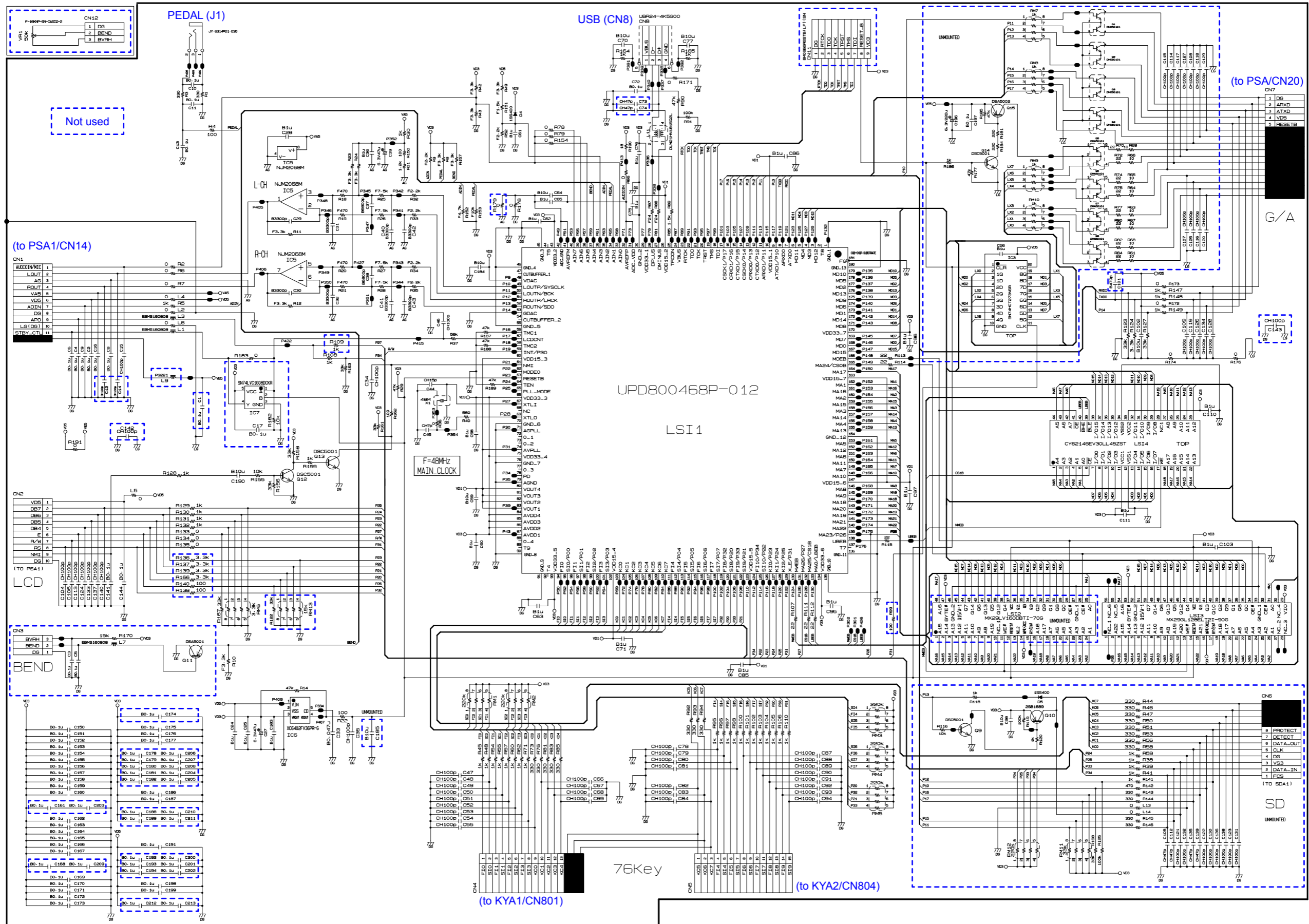

Power & Amp PCB: M829-PSA1 (1/2)

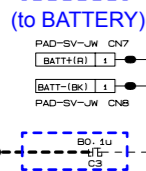
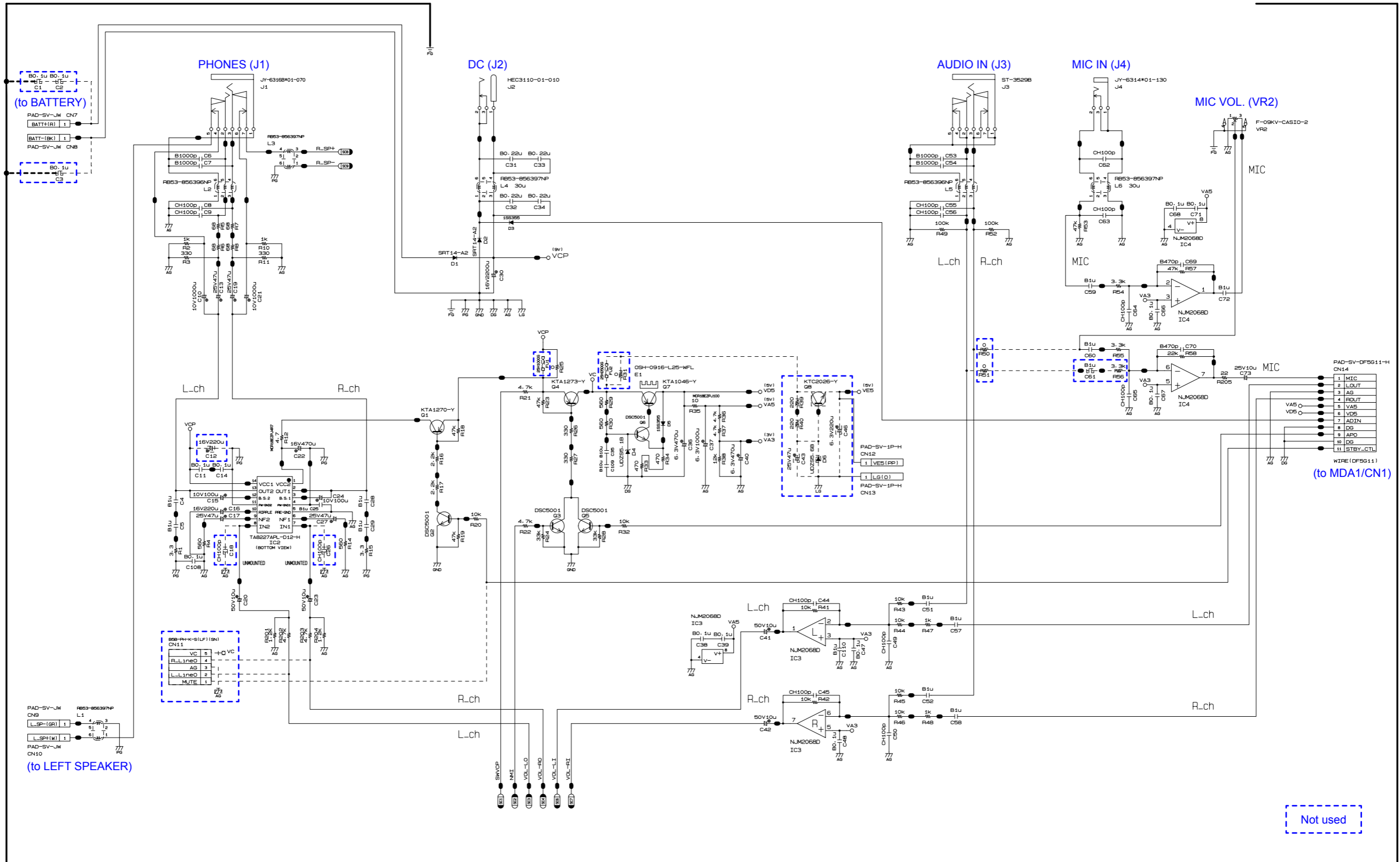

(to LEFT SPEAKER)

LEFT SPEAKER

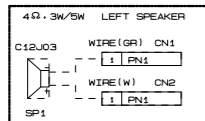

BATTERY

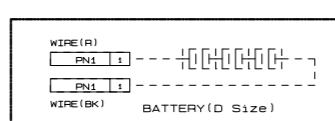

RIGHT SPEAKER

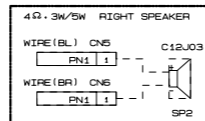

Not used

Power & Amp PCB: M829-PSA1 (2/2)

JUMPER RESISTOR MCR03EZPJ000

0 _W R439	0 _W R478	0 _W R479	0 _W R470
0 _W R483	0 _W R484	0 _W R485	0 _W R486
0 _W R487	0 _W R488	0 _W R489	0 _W R490

JUMPER RESISTOR MCR18EZPJ000

0 _W R401	0 _W R402	0 _W R403	0 _W R404	0 _W R405
0 _W R406	0 _W R407	0 _W R408	0 _W R409	0 _W R410
0 _W R411	0 _W R412	0 _W R413	0 _W R414	0 _W R415
0 _W R416	0 _W R417	0 _W R418	0 _W R419	0 _W R420
0 _W R421	0 _W R422	0 _W R423	0 _W R424	0 _W R425
0 _W R426	0 _W R427	0 _W R428	0 _W R429	0 _W R430
0 _W R431	0 _W R432	0 _W R433	0 _W R434	0 _W R435
0 _W R436	0 _W R437	0 _W R438	0 _W R439	0 _W R440
0 _W R441	0 _W R442	0 _W R443	0 _W R444	0 _W R445
0 _W R446	0 _W R447	0 _W R448	0 _W R449	0 _W R450
0 _W R451	0 _W R452	0 _W R453	0 _W R454	0 _W R455
0 _W R456	0 _W R457	0 _W R458	0 _W R459	0 _W R460
0 _W R461	0 _W R462	0 _W R463	0 _W R464	0 _W R465
0 _W R466	0 _W R467	0 _W R468	0 _W R469	0 _W R470
0 _W R471	0 _W R472	0 _W R473	0 _W R474	0 _W R475
0 _W R476	0 _W R477	0 _W R478	0 _W R479	0 _W R480
0 _W R481	0 _W R482	0 _W R483	0 _W R484	0 _W R485
0 _W R491	0 _W R492	0 _W R493	0 _W R494	0 _W R495

Not used

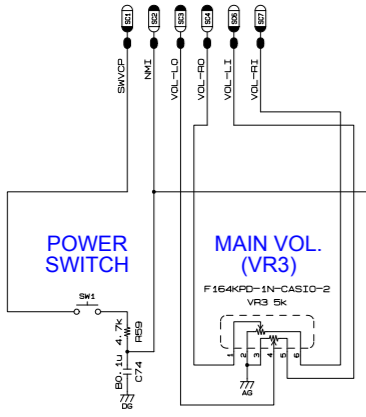
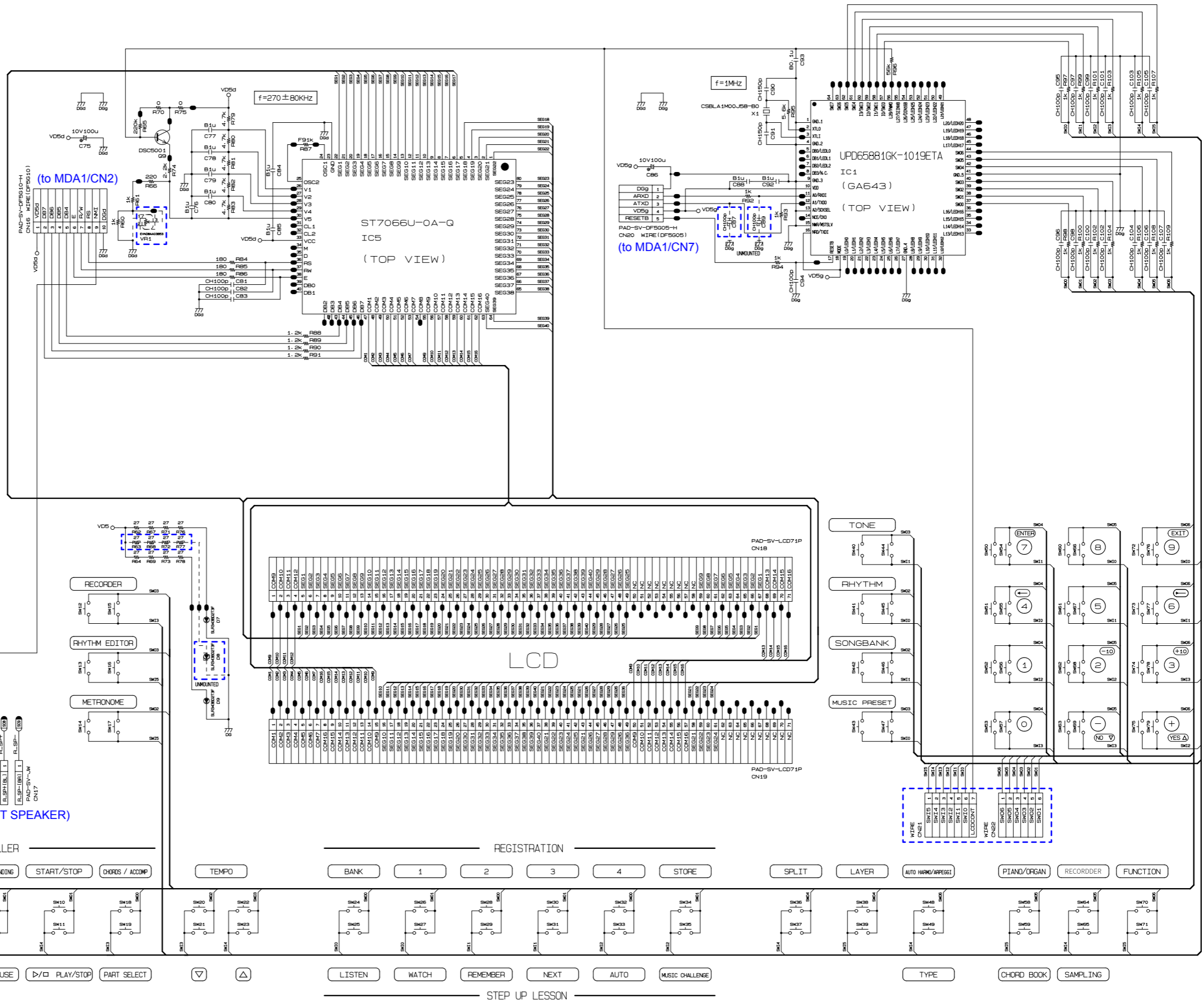

(to RIGHT SPEAKER)

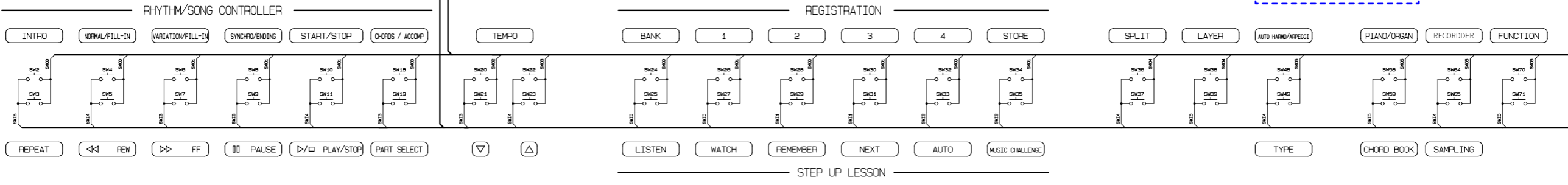
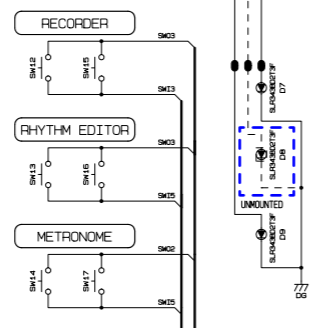

Keyboard PCB: M709-KYA1 / KYA2

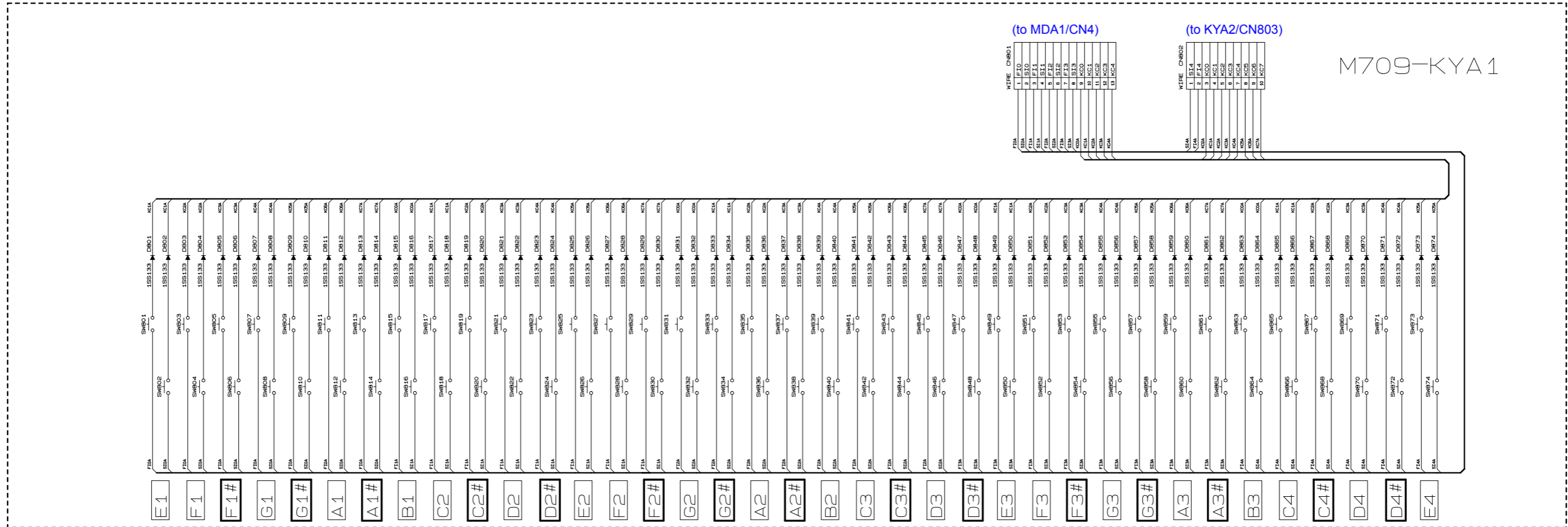
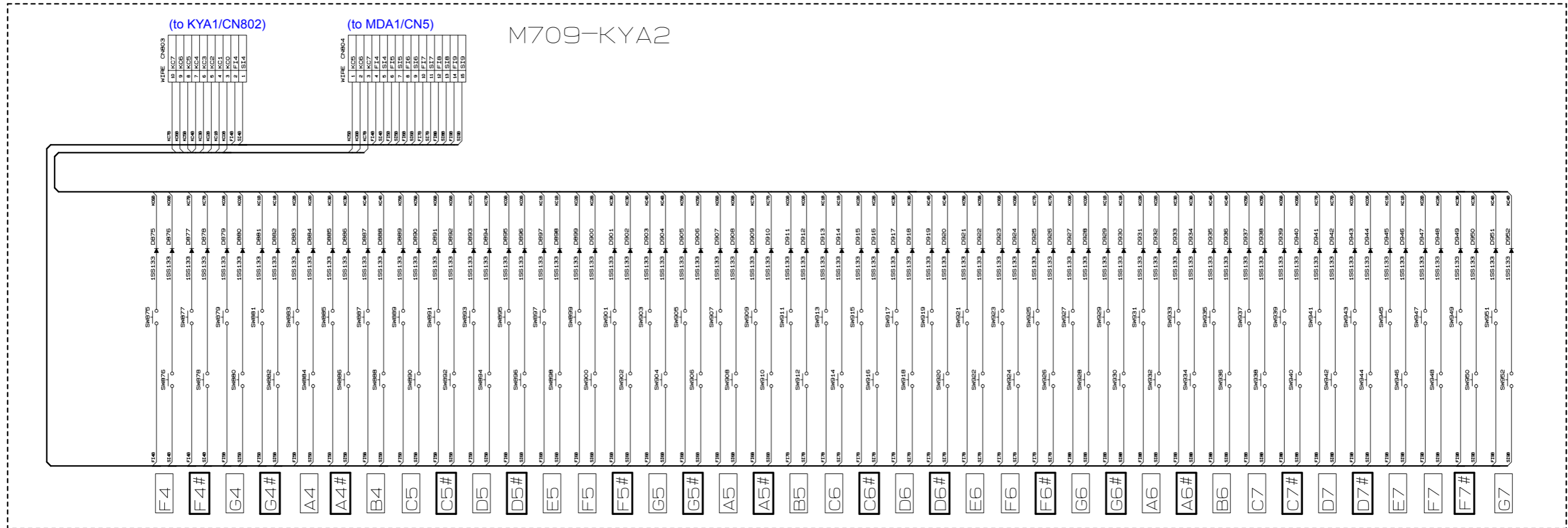

Ver. 1 : Jul. 2014

- Correction of CIRCUIT DESCRIPTION (P5)
- Correction of PARTS LIST (P34)

CASIO COMPUTER CO., LTD.

CS Technical Department

TOKYO, JAPAN